

ARI-REYCO™

Direct Spring Acting Safety Relief Valves
for Gas, Liquid, and Steam Service

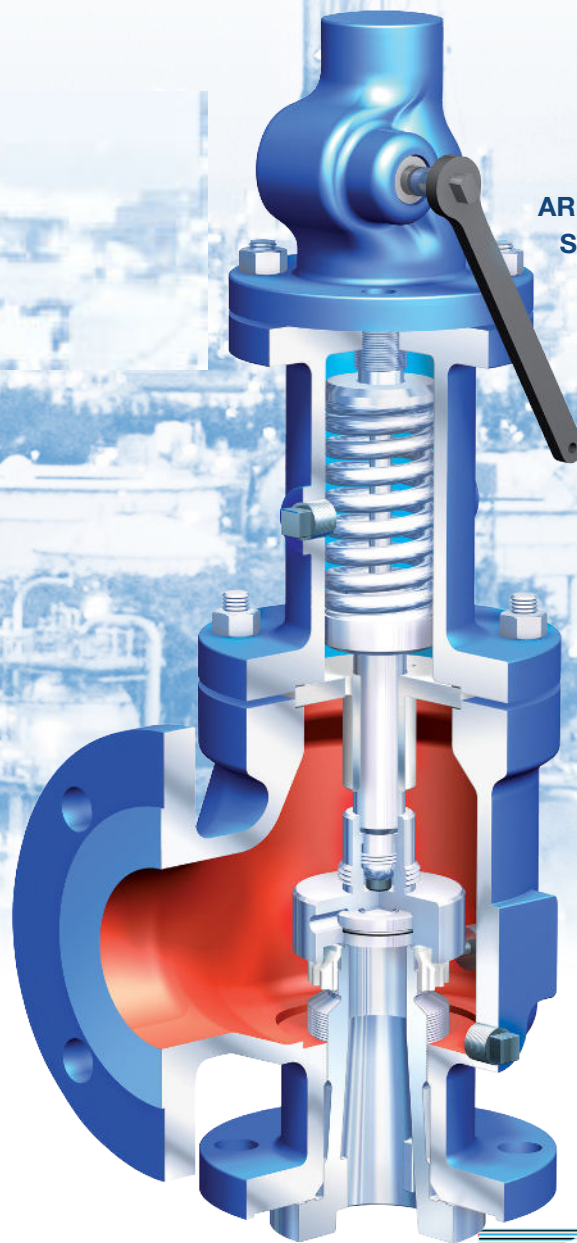

ARI-REYCO™
SERIES R

ASME SECTION VIII / API 526



ARI-REYCO™

Direct Spring Acting Safety Relief Valves
for Gas, Liquid, and Steam Service

Series R, RO, RB, RBO, & RS



About ARI-Reyco

The ARI-Reyco line of direct spring acting pressure relief valves utilizes sound engineering principles and undergoes thorough testing and continuous quality control in manufacturing. These measures ensure that ARI-Reyco valves deliver the precision, durability, and value our customers expect and demand.

For more information about the complete line of products and services by ARI-Reyco, visit our web site or contact the sales representative nearest you.

www.ari-armaturenusa.com

www.reycovalve.com

ARI-Armaturen USA, LP
6614 Dixie Drive
Houston, TX 77087

T 713.845.1500

F 713.845.1515

E sales@ari-armaturenusa.com

ARI-Reyco valves are built to established industry standards and codes.



UV



ISO 9001:2008 Certified



Direct Spring Acting Pressure Relief Valve

R, RO, RB, RBO, and RS Series

Table of Contents

Operating Principles	2
Features and Benefits	4
Valve Diagrams	
R Series	5
RB Series	6
RS Series	7
Model Number Guide	8
Valve Selector	
D Orifice	10
E Orifice	11
F Orifice	12
G Orifice	13
H Orifice	14
J Orifice	15
K Orifice	16
L Orifice	17
M Orifice	18
N Orifice	19
P Orifice	20
Q Orifice	21
R Orifice	22
T Orifice	23
Bill of Materials	
R & RB Series Standard Trim	24
Carbon Steel and Stainless Steel Trim	26
Monel [®] Trim	27
Hastelloy [®] C Trim	28
Duplex Trim	29
Alloy 20 Trim	30
Low Temperature	31
NACE Trim and High Temperature Trim	32
Options	
Lifting Levers and Cap Options	33
Lift Lever Materials	34
O-Ring Seat Seals	37
O-Ring Selector Chart	38
Technical Information	
Procedures for Sizing Safety Relief Valves	39
Sizing and Selection by Formula	40
Superheated Steam Sizing Correction Table	42
Capacity Charts	44

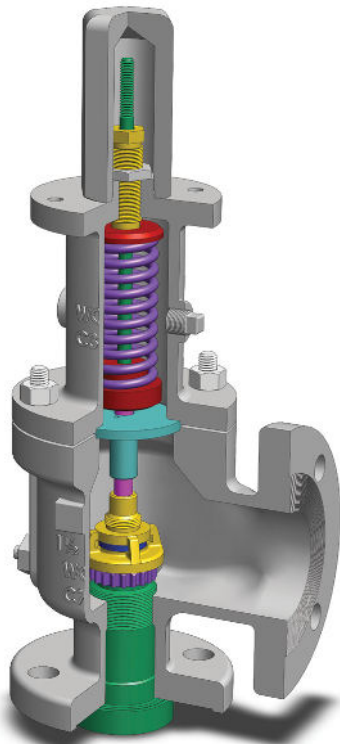

R Series Pressure Relief Valve

The Series R/RB pressure relief valve consists of a nozzle threaded into a cast body housing which is flanged to a pressurized system. A disc is held against the nozzle by a spring, which is contained in a cast bonnet. The spring is adjusted by a compression screw to permit the calibration of opening or set pressure. An adjustable nozzle ring, threaded onto the nozzle, controls the geometry of the fluid exit control chamber (huddling chamber). The huddling chamber geometry is very important in controlling valve opening and closing pressures and stability of operation. The nozzle ring is locked into position by a ring pin assembly. A cap attached to the top of the bonnet seals the internal calibration adjustments. Refer to the figure at left, or to the illustration on page 5, for the location of these important components.

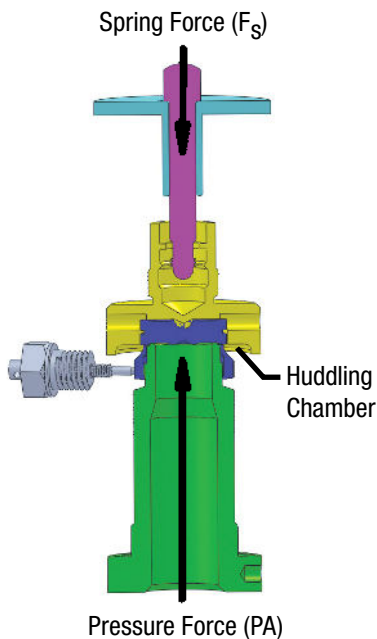

Under normal system operation the valve remains in the closed position because the spring force (F_s) is greater than the system pressure acting on the internal nozzle seating area (PA). If system pressure increases to a point when these forces are equal, then the set pressure is reached. The disc lifts and fluid flows through the valve. When pressure in the system returns to a safe level, the valve closes.

Just prior to reaching set point, the pressure relief valve leaks system fluid into the huddling chamber. The fluid now acts on a larger area of the disc inside the huddling chamber (PA_h), causing the valve to experience an instantaneous increase in the opening force. Refer to the figure on page 3 to see relationship between Nozzle Area (A) and the Huddling Chamber Area (A_h). System pressure acting on the larger area will suddenly open the safety relief valve at a rapid rate.

Although the opening is rapid and dramatic, the valve does not open fully at set point. The system pressure must increase above set point to open the valve to its full lift and capacity position. Maximum lift and certified flow rates will be achieved within the allowable limits (overpressure) established by various codes and standards. All pressure relief valves are allowed an overpressure allowance to reach full rated flow. The allowable over pressure can vary from 10% to 21% on unfired vessels and systems, depending on the sizing basis, number of valves, and whether a fire condition is encountered.

Once the valve has controlled the pressure excursion, system pressure will start to reduce. Since the huddling chamber area is now controlling the exit fluid flow, system pressure must reduce below the set point before the spring force is able to close the valve. The difference between the set pressure and the closing pressure is called blowdown, and is usually expressed as a percentage of set pressure.

In the Series R/RB, the nozzle ring adjustment changes the shape and volume of the huddling chamber, and its position will affect both the opening and the closing characteristics of the valve. When the nozzle ring is adjusted to its top position, the huddling chamber is restricted to its maximum. The Series R/RB will usually pop very distinctly with a minimum simmer (leakage before opening), but the blowdown will increase. When the nozzle ring is lowered to its lowest position, minimal restriction to the huddling chamber occurs. At this position, simmer increases and the blowdown decreases. The final ring position is somewhere between these two extremes to provide optimal performance.

Liquid Service Operation

On liquid service, a different dynamic situation exists. Liquids do not expand when flowing across orifices, and a small amount of fluid flow across the nozzle will produce a large local pressure drop at the nozzle orifice. This local pressure drop causes the spring to reclose the valve if the fluid flow is minimal. Liquids leaking into the huddling chamber can quickly drain out by gravity and prevent fluid pressure from building up in the secondary area of the huddling chamber. Liquid relief valves are thus susceptible to a phenomenon called chatter, especially at low fluid flow rates. Chatter is the rapid opening and closing of the pressure relief valve and is always destructive.

The unique design of the Series R/RB disc holder and nozzle ring retains the fluid within the huddling chamber, *without conversion to a special liquid trim. ASME Code Section VIII performance criteria of full rated liquid flow at 10% overpressure is met with the standard trim, unlike almost all other major manufacturers.*

Since no visible or audible pop is heard at set point, the Series R/RB liquid set pressure is defined as the pressure when the first heavy flow occurs (a pencil sized steady stream of water that remains unbroken for approximately one inch).

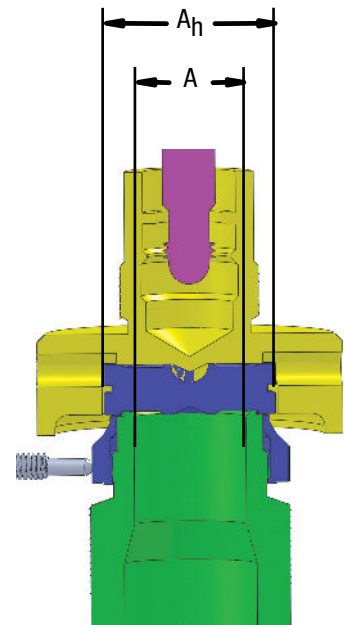

Relationship of Nozzle Area to Huddling Chamber Area

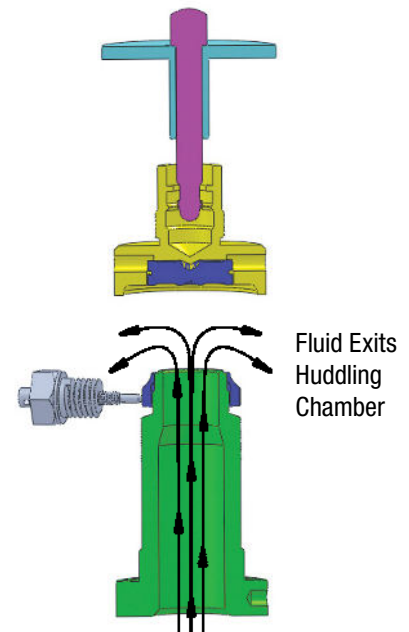

Valve Opens, Force PA_h Acting on Disc

Features and Benefits

Features and Benefits

- Single trim for all services provides full capacity at 10% overpressure for liquid, steam, or vapor applications.
- Reversible disc provides a spare part in every valve.
- Nozzle threads at top ensure better nozzle/body alignment and reduce maintenance effort.
- Disc retention by ring eliminates potential of thread corrosion and need for special maintenance tools.
- Standard Inconel® 625 LCF Bellows offers better corrosion resistance than 316L SS **at no extra cost.**
- Springs within a pressure class and orifice size are designed with a fixed I.D. to eliminate the need to custom-machine steps for each spring.
- Identical nozzle ring for each orifice size, regardless of pressure range or seat design, to reduce parts variation.
- In the soft seat option, the spring load is applied directly to the metal seat, increasing service life of the O-ring. The soft seat disc retains the metal seat on its reversible side.

General Specifications

- ASME VIII UV Certified
- Pressure Equipment Directive 97/23/CE Certified
- ISO 9001:2008 Certified
- API 526 Compliant
- 1-inch D 2-inch through 8-inch T 10-inch [25mm D 50mm though 200mm T 250mm]
- Optional soft seats
- CS, Alloy Steel, and 316 SS are standard materials
- Lift levers, test gags, steam jackets, and other accessories available
- Monel®, Hastelloy® C, and Duplex SS materials for corrosive applications
- ANSI/NACE MR0175/ISO 15156 and MR-0103 compliant trim available
- Cryogenic materials available
- Canadian Registration Numbers (CRN) available.

Technical Data

R Series

Conventional design

RO Series (see note 4)

Conventional design, soft seat

RB Series

Balanced bellows design

RBO Series (see note 4)

Balanced bellows design, soft seat

RS Series

Open bonnet for steam service

Notes

1. Inconel® and Monel® are registered trademarks of Special Metals Corporation.
2. Hastelloy® is a registered trademark of Haynes International.
3. Pressure rating on pages 12-25 are based on A216-WCC & WC6 materials. Consult ANSI B16.34 for pressure ratings of other materials, (316, Monel®, Hastelloy® C, WC6, etc.).
4. See page 37 for additional information.

R Series

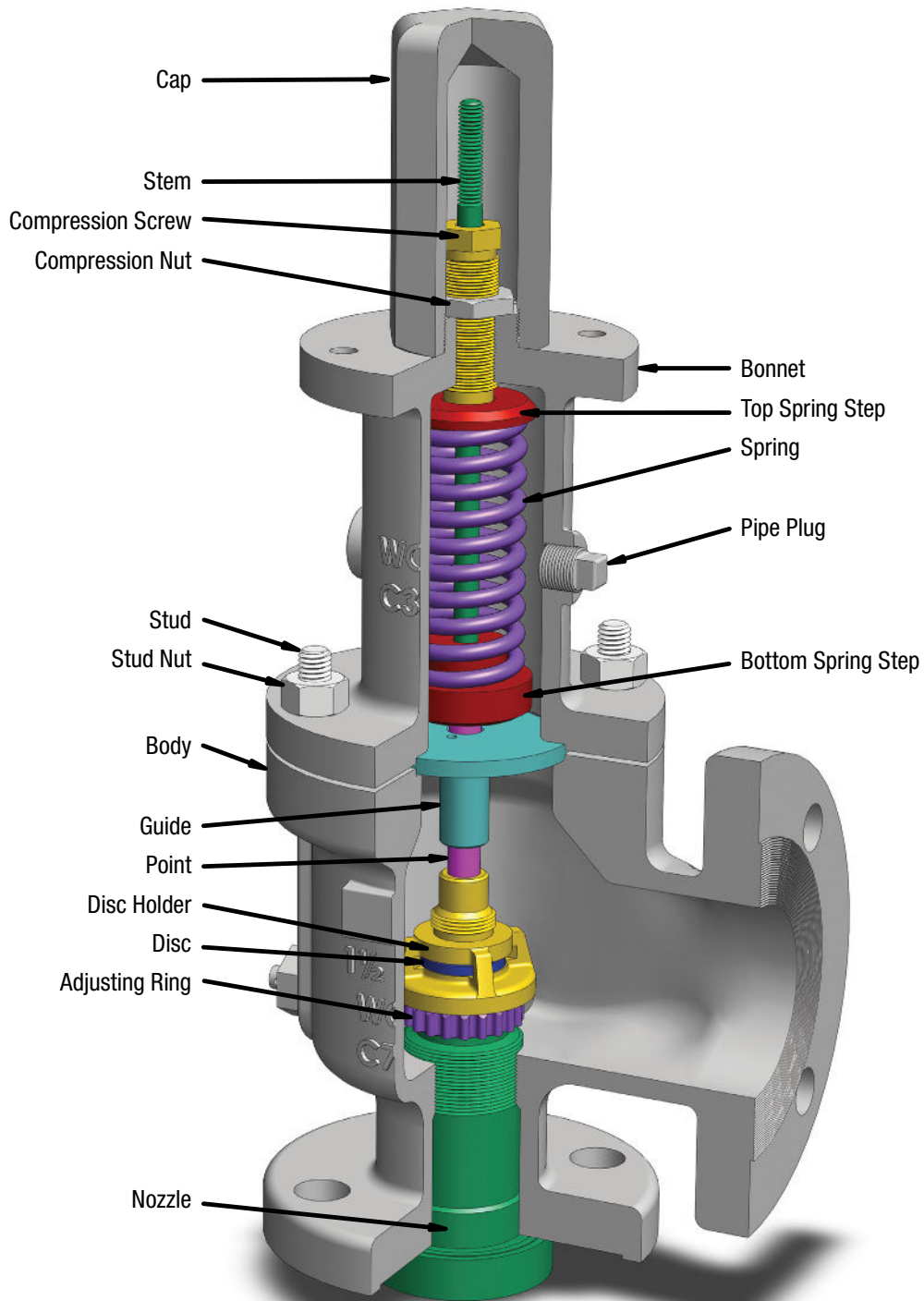

Valve Diagrams

RB Series

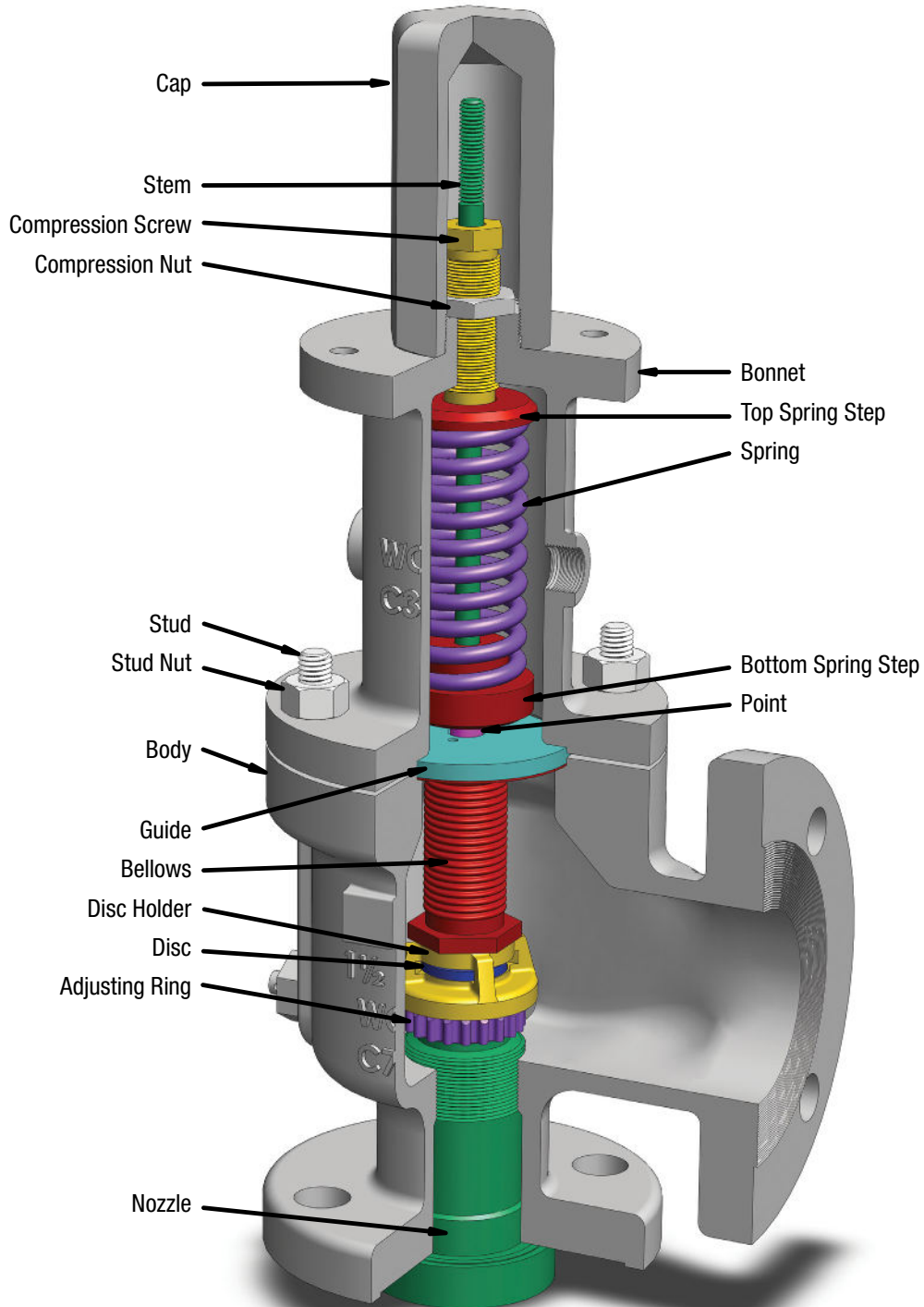

Valve Diagrams

RS Series

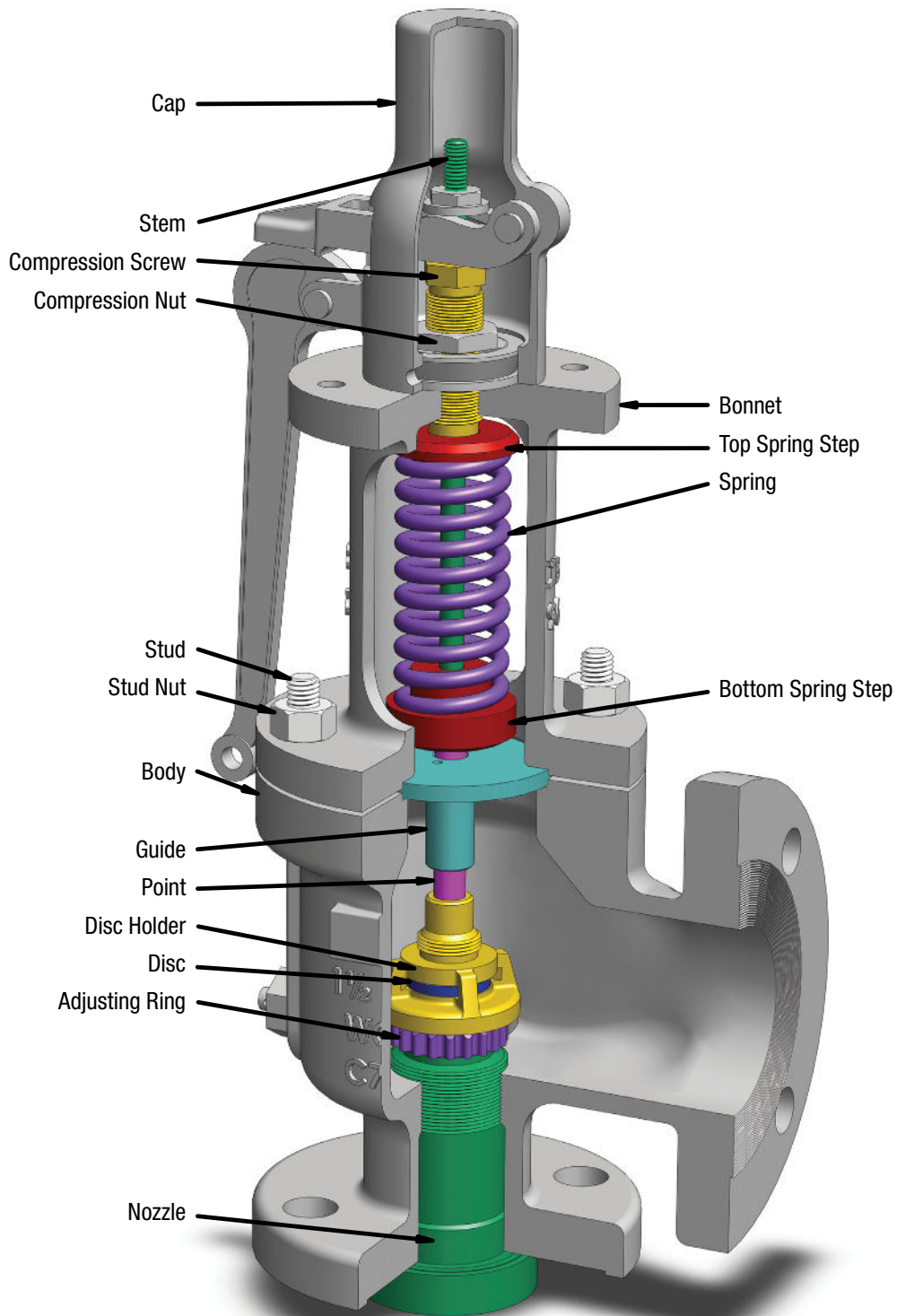

R Series Model Number Guide

Valve Type

- R-** Conventional Valve, Enclosed Spring
- RO** Conventional Valve, Enclosed Spring, O-ring Seat (see note 1)
- RB** Balanced Bellows, Enclosed Spring
- RBO** Balanced Bellows, Enclosed Spring, O-ring Seat (see note 1)
- RS** Open Bonnet, Exposed Spring

Inlet/Outlet Connections (RF connections are standard)

- | | |
|---|--|
| 1 ANSI Class 150 × 150 | 5 ANSI Class 600 × 150 (see note 2) |
| 2 ANSI Class 300LW
(285 psig max) × 150 | 7 ANSI Class 900 × 150 or ANSI Class 900 x 300 (see note 3) |
| 3 ANSI Class 300 × 150 | 8 ANSI Class 1500 × 300 or ANSI Class 1500 x 150 (see note 4) |
| | 9 ANSI Class 2500 × 300 |

Temperature Range

- 0** -20°F to +450°F [-29°C to +232°C]
- 1** +450°F to +650°F [+232°C to +343°C]
- 2** +650°F to +800°F [+343°C to +427°C]
- 3** +800°F to +1000°F [+427°C to +538°C]
- 4** -400°F to -21°F [-240°C to -29°C]

Standard API 526 Orifice Sizing (Actual Size)

D 0.110 in ² (0.122 in ²)	J 1.287 in ² (1.427 in ²)	P 6.38 in ² (7.07 in ²)
E 0.196 in ² (0.217 in ²)	K 1.838 in ² (2.036 in ²)	Q 11.05 in ² (12.24 in ²)
F 0.307 in ² (0.340 in ²)	L 2.853 in ² (3.160 in ²)	R 16.00 in ² (17.72 in ²)
G 0.503 in ² (0.558 in ²)	M 3.60 in ² (3.987 in ²)	T 26.00 in ² (29.75 in ²)
H 0.785 in ² (0.869 in ²)	N 4.34 in ² (4.807 in ²)	

Materials (see note 5) + Description (see note 5)

S 316 SS	1 Disc and Nozzle, WCC Body & Bonnet 2 Internal Parts except Spring & Steps WCC Body & Bonnet 3 Complete Valve except Spring & Steps 4 Entire Valve 5 All Parts below Bellows
M Monel®	
H Hastelloy® C	
D Duplex	
A Alloy 20	
L Low Temperature	1 316 SS body, WCC Bonnet & Cap 2 All 316 SS, except Inconel® Bellows 3 Entire Valve Stainless Steel, including Bellows C LCC Body, Bonnet, and Cap
S NACE MR-01-75 NACE MR-01-03	G Carbon Steel Body & Bonnet S Stainless Steel Body & Bonnet
W High Temperature	1 WC6 Body, WCC Bonnet & Cap, 316 SS Internals 2 WC6 Body & Bonnet, WCC Cap, 316 SS Internals

R - 1 0 D S 1 (Model number continued on next page)

R Series Model Number Guide

Configurations

- 2 Standard
- B 2.5" Inlet
- C 2.5" Outlet
- E RTJ Inlet
- F RTJ Outlet
- G RTJ Inlet & Outlet
- H Special Inlet and/or Outlet Configuration
- J Jacketed Valve
- ...
- Z Other Special/Nonstandard Options

Cap/Lever Options

- 0 Screwed Cap without Gag
- 1 Screwed Cap with Gag
- 2 Open Lift Lever without Gag
- 3 Open Lift Lever with Gag
- 4 Packed Lift Lever without Gag
- 5 Packed Lift Lever with Gag
- 8 Bolted Cap without Gag
- 9 Bolted Cap with Gag

Design Revision

- One-piece Stem
- A Reyco Valve, Two-piece Stem
- C ARI-Reyco Design

Service

- J ASME Section VIII Liquid
- K ASME Section VIII Gas and Vapors
- L ASME Section VIII Steam (Limited to 2900 psig [200 barg])
- M Non Code Liquid
- N Non Code Gas, Vapor
- P Non Code Steam

Spring Material

- | | | |
|-------------------|-----------------------|-------------------|
| A Alloy 20 | G 316 Stainless Steel | Z Other Materials |
| B Inconel® X-750 | H Hastelloy® | |
| C Chrome Vanadium | S Coated Steel | |

Set Pressure, i.e.

- 0008 = 8 psig
- 0015 = 15 psig
- 0125 = 125 psig
- 6000 = 6000 psig

Notes

1. The standard soft seat material in Models RO and RBO is Viton®.
2. For T-orifice valves, Inlet/Outlet rating code 'S' is an ANSI 300 × 150, not ANSI 600 × 150.
3. Orifices D through G have ANSI Class 300 Outlets. Orifices H through P have ANSI Class 150 Outlets.
4. Orifices D through K have ANSI Class 300 Outlets. Orifice L has an ANSI Class 150 Outlet.
5. Other materials available upon request. Additional information can be found in the Bill of Materials on pages 24–32.

2 0 C K A 0200

D Orifice

316 SS or WC6 Body & Bonnet;
Alloy Spring

Carbon Steel Body & Bonnet;
Alloy Spring

Carbon Steel Body & Bonnet;
Chrome Vanadium Spring

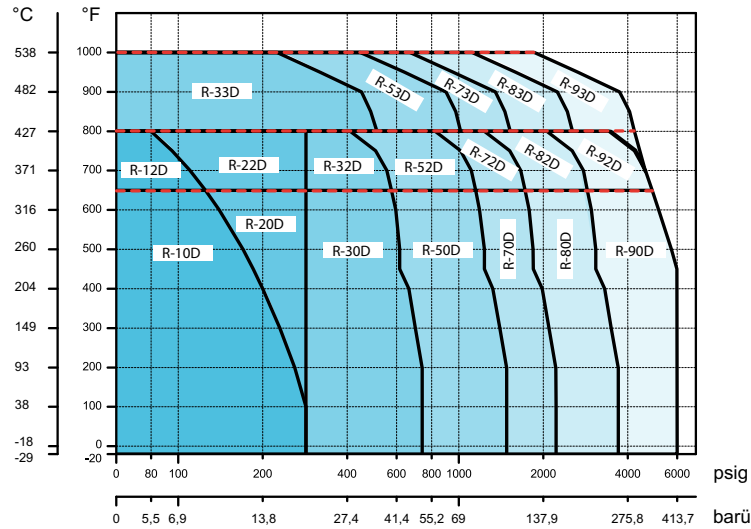

Specifications

Valve Size (inches)	Valve Model		Flange Connections ANSI Std. (RF or RTJ)		Maximum Set Pressure (psig)				Max. Back Pressure (psig @ 100°F)		Valve Dimensions (inches)			Weight (lb)
	Conv.	Bellows	Inlet	Outlet	100°F	650°F	800°F	1000°F	Conv.	Bellows	A	B	Max. C	
1 × 2	R-10D	RB10D	150	150	285	125			285	230	4 1/8	4 1/2	20	40
1 × 2	R-12D	RB12D	150	150		125	80		285	230	4 1/8	4 1/2	20	40
1 × 2	R-20D	RB20D	300LW	150	285	285			285	230	4 1/8	4 1/2	20	43
1 × 2	R-22D	RB22D	300LW	150	285	285			285	230	4 1/8	4 1/2	20	43
1 × 2	R-30D	RB30D	300	150	740	590			285	230	4 1/8	4 1/2	20	45
1 × 2	R-32D	RB32D	300	150		590	410		285	230	4 1/8	4 1/2	20	45
1 × 2	R-33D	RB33D	300	150			510	215	285	230	4 1/8	4 1/2	20	45
1 × 2	R-50D	RB50D	600	150	1480	1175			285	230	4 1/8	4 1/2	20	45
1 × 2	R-52D	RB52D	600	150		1175	825		285	230	4 1/8	4 1/2	20	45
1 × 2	R-53D	RB53D	600	150			1015	430	285	230	4 1/8	4 1/2	20	45
1.5 × 2	R-70D	RB70D	900	300	2220	1765			600	500	4 1/8	5 1/2	20	58
1.5 × 2	R-72D	RB72D	900	300		1765	1235		600	500	4 1/8	5 1/2	20	58
1.5 × 2	R-73D	RB73D	900	300			1525	650	600	500	4 1/8	5 1/2	20	58
1.5 × 2	R-80D	RB80D	1500	300	3705	2940			600	500	4 1/8	5 1/2	20	58
1.5 × 2	R-82D	RB82D	1500	300		2940	2055		600	500	4 1/8	5 1/2	20	58
1.5 × 2	R-83D	RB83D	1500	300			2540	1080	600	500	4 1/8	5 1/2	20	58
1.5 × 3	R-90D	RB90D	2500	300	6000	4905			740	500	5 1/2	7	22 1/2	80
1.5 × 3	R-92D	RB92D	2500	300		4905	3430		740	500	5 1/2	7	22 1/2	80
1.5 × 3	R-93D	RB93D	2500	300			4230	1800	740	500	5 1/2	7	22 1/2	80

Notes

- Valves set under 15 psig are not ASME code stamped.
- Valve dimension C for RB bellows valves add 3/4-inch. Maximum A and B dimensions ± 1/16-inch.

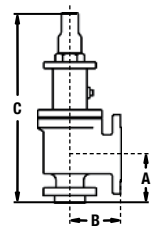

Valve Selector

E Orifice

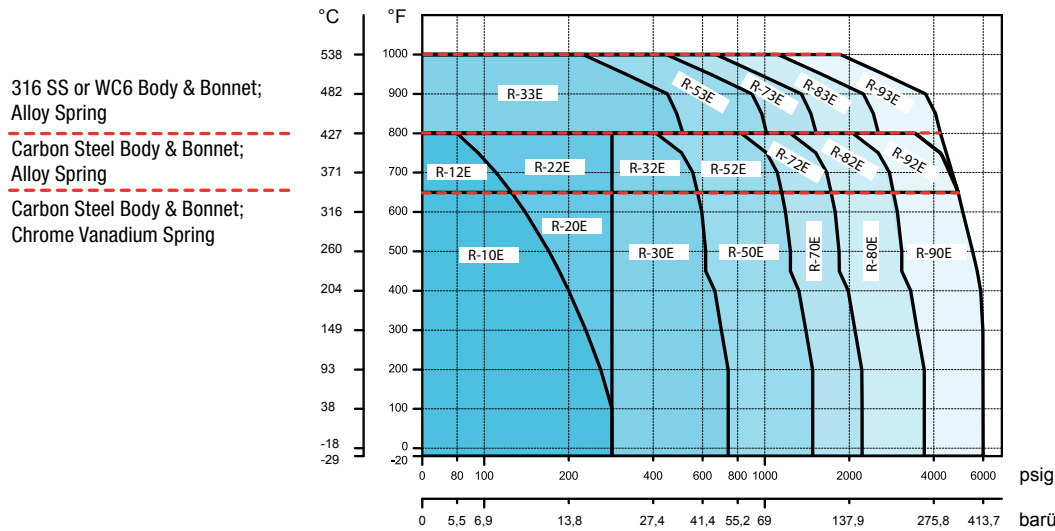

Specifications

Valve Size (inches)	Valve Model Conv.	Valve Model Bellows	Flange Connections ANSI Std. (RF or RTJ)		Maximum Set Pressure (psig)				Max. Back Pressure (psig @ 100°F)		Valve Dimensions (inches)			Weight (lb)
			Inlet	Outlet	100°F	650°F	800°F	1000°F	Conv.	Bellows	A	B	Max. C	
1 × 2	R-10E	RB10E	150	150	285	125			285	230	4 1/8	4 1/2	20	40
1 × 2	R-12E	RB12E	150	150		125	80		285	230	4 1/8	4 1/2	20	40
1 × 2	R-20E	RB20E	300LW	150	285	285			285	230	4 1/8	4 1/2	20	43
1 × 2	R-22E	RB22E	300LW	150	285	285			285	230	4 1/8	4 1/2	20	43
1 × 2	R-30E	RB30E	300	150	740	590			285	230	4 1/8	4 1/2	20	45
1 × 2	R-32E	RB32E	300	150		590	410		285	230	4 1/8	4 1/2	20	45
1 × 2	R-33E	RB33E	300	150			510	215	285	230	4 1/8	4 1/2	20	45
1 × 2	R-50E	RB50E	600	150	1480	1175			285	230	4 1/8	4 1/2	20	45
1 × 2	R-52E	RB52E	600	150		1175	825		285	230	4 1/8	4 1/2	20	45
1 × 2	R-53E	RB53E	600	150			1015	430	285	230	4 1/8	4 1/2	20	45
1.5 × 2	R-70E	RB70E	900	300	2220	1765			600	500	4 1/8	5 1/2	20	58
1.5 × 2	R-72E	RB72E	900	300		1765	1235		600	500	4 1/8	5 1/2	20	58
1.5 × 2	R-73E	RB73E	900	300			1525	650	600	500	4 1/8	5 1/2	20	58
1.5 × 2	R-80E	RB80E	1500	300	3705	2940			600	500	4 1/8	5 1/2	20	58
1.5 × 2	R-82E	RB82E	1500	300		2940	2055		600	500	4 1/8	5 1/2	20	58
1.5 × 2	R-83E	RB83E	1500	300			2540	1080	600	500	4 1/8	5 1/2	20	58
1.5 × 3	R-90E	RB90E	2500	300	6000	4905			740	500	5 1/2	7	22 1/2	80
1.5 × 3	R-92E	RB92E	2500	300		4905	3430		740	500	5 1/2	7	22 1/2	80
1.5 × 3	R-93E	RB93E	2500	300			4230	1800	740	500	5 1/2	7	22 1/2	80

Notes

1. Valves set under 15 psig are not ASME code stamped.
2. Valve dimension C for RB bellows valves add 3/4-inch. Maximum A and B dimensions ± 1/16-inch.

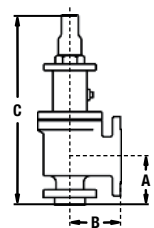

F Orifice

316 SS or WC6 Body & Bonnet;
Alloy Spring

Carbon Steel Body & Bonnet;
Alloy Spring

Carbon Steel Body & Bonnet;
Chrome Vanadium Spring

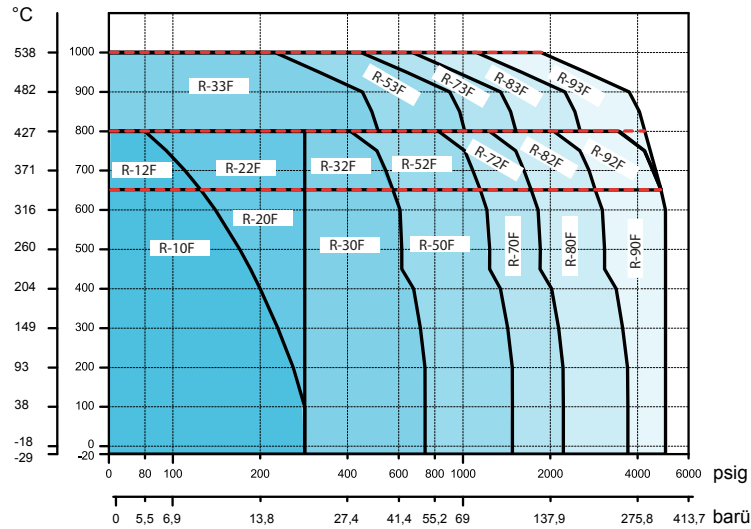

Specifications

Valve Size (inches)	Valve Model		Flange Connections ANSI Std. (RF or RTJ)		Maximum Set Pressure (psig)				Max. Back Pressure (psig @ 100°F)		Valve Dimensions (inches)			Weight (lb)
	Conv.	Bellows	Inlet	Outlet	100°F	650°F	800°F	1000°F	Conv.	Bellows	A	B	Max. C	
1.5 × 2	R-10F	RB10F	150	150	285	125			285	230	4 7/8	4 3/4	20 3/4	43
1.5 × 2	R-12F	RB12F	150	150		125	80		285	230	4 7/8	4 3/4	20 3/4	43
1.5 × 2	R-20F	RB20F	300LW	150	285	285			285	230	4 7/8	4 3/4	20 3/4	47
1.5 × 2	R-22F	RB22F	300LW	150	285	285			285	230	4 7/8	4 3/4	20 3/4	47
1.5 × 2	R-30F	RB30F	300	150	740	590			285	230	4 7/8	6	20 3/4	50
1.5 × 2	R-32F	RB32F	300	150		590	410		285	230	4 7/8	6	20 3/4	50
1.5 × 2	R-33F	RB33F	300	150			510	215	285	230	4 7/8	6	20 3/4	50
1.5 × 2	R-50F	RB50F	600	150	1480	1175			285	230	4 7/8	6	20 3/4	50
1.5 × 2	R-52F	RB52F	600	150		1175	825		285	230	4 7/8	6	20 3/4	50
1.5 × 2	R-53F	RB53F	600	150			1015	430	285	230	4 7/8	6	20 3/4	50
1.5 × 3	R-70F	RB70F	900	300	2220	1765			740	500	4 7/8	6 1/2	20 3/8	63
1.5 × 3	R-72F	RB72F	900	300		1765	1235		740	500	4 7/8	6 1/2	20 3/8	63
1.5 × 3	R-73F	RB73F	900	300			1525	650	740	500	4 7/8	6 1/2	20 3/8	63
1.5 × 3	R-80F	RB80F	1500	300	3705	2940			740	500	4 7/8	6 1/2	21 3/4	68
1.5 × 3	R-82F	RB82F	1500	300		2940	2055		740	500	4 7/8	6 1/2	21 3/4	68
1.5 × 3	R-83F	RB83F	1500	300			2540	1080	740	500	4 7/8	6 1/2	20 3/8	63
1.5 × 3	R-90F	RB90F	2500	300	5000	4905			740	500	5 1/2	7	22 1/2	80
1.5 × 3	R-92F	RB92F	2500	300		4905	3430		740	500	5 1/2	7	22 1/2	80
1.5 × 3	R-93F	RB93F	2500	300			4230	1800	740	500	5 1/2	7	22 1/2	80

Notes

1. Valves set under 15 psig are not ASME code stamped.
2. Maximum A and B dimensions ± 1/16-inch.
3. API 526 eliminated 2 1/2-inch flange sizes, however ARI-Reyco will supply 2 1/2-inch flange sizes.

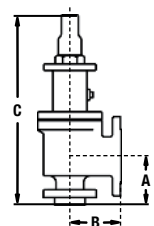

G Orifice

316 SS or WC6 Body & Bonnet;
Alloy Spring

Carbon Steel Body & Bonnet;
Alloy Spring

Carbon Steel Body & Bonnet;
Chrome Vanadium Spring

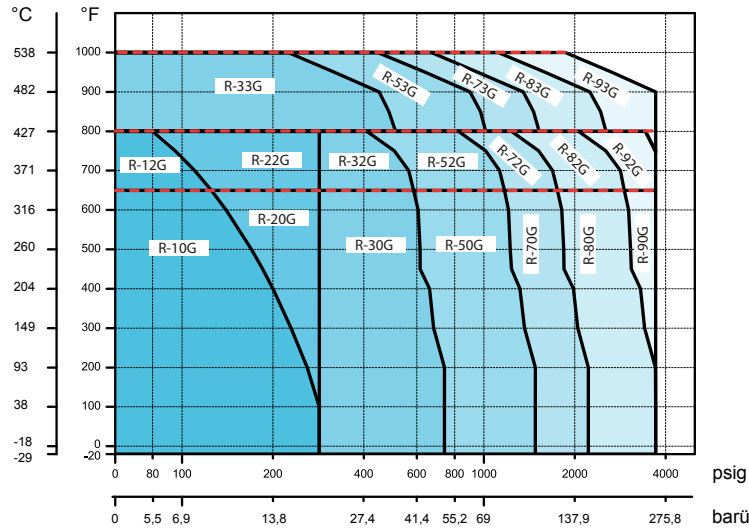

Specifications

Valve Size (inches)	Valve Model		Flange Connections ANSI Std. (RF or RTJ)		Maximum Set Pressure (psig)				Max. Back Pressure (psig @ 100°F)		Valve Dimensions (inches)			Weight (lb)
	Conv.	Bellows	Inlet	Outlet	100°F	650°F	800°F	1000°F	Conv.	Bellows	A	B	Max. C	
1.5 × 3	R-10G	RB10G	150	150	285	125			285	230	4 7/8	4 3/4	20 3/4	46
1.5 × 3	R-12G	RB12G	150	150		125	80		285	230	4 7/8	4 3/4	20 3/4	46
1.5 × 3	R-20G	RB20G	300LW	150	285	285			285	230	4 7/8	4 3/4	20 3/4	50
1.5 × 3	R-22G	RB22G	300LW	150	285	285			285	230	4 7/8	4 3/4	20 3/4	50
1.5 × 3	R-30G	RB30G	300	150	740	590			285	230	4 7/8	6	20 3/4	55
1.5 × 3	R-32G	RB32G	300	150		590	410		285	230	4 7/8	6	20 3/4	55
1.5 × 3	R-33G	RB33G	300	150			510	215	285	230	4 7/8	6	20 3/4	55
1.5 × 3	R-50G	RB50G	600	150	1480	1175			285	230	4 7/8	6	20 3/4	55
1.5 × 3	R-52G	RB52G	600	150		1175	825		285	230	4 7/8	6	20 3/4	55
1.5 × 3	R-53G	RB53G	600	150			1015	430	285	230	4 7/8	6	20 3/4	55
1.5 × 3	R-70G	RB70G	900	300	2220	1765			740	470	4 7/8	6 1/2	21 3/4	67
1.5 × 3	R-72G	RB72G	900	300		1765	1235		740	470	4 7/8	6 1/2	21 3/4	67
1.5 × 3	R-73G	RB73G	900	300			1525	650	740	500	4 7/8	6 1/2	21 3/4	67
2 × 3	R-80G	RB80G	1500	300	3705	2940			740	470	6 1/8	6 3/4	25 1/2	140
2 × 3	R-82G	RB82G	1500	300		2940	2055		740	470	6 1/8	6 3/4	25 1/2	140
2 × 3	R-83G	RB83G	1500	300			2540	1080	740	500	6 1/8	6 3/4	25 1/2	140
2 × 3	R-90G	RB90G	2500	300	3705	3705			740	470	6 1/8	6 3/4	25 1/2	155
2 × 3	R-92G	RB92G	2500	300		3705	3430		740	470	6 1/8	6 3/4	25 1/2	155
2 × 3	R-93G	RB93G	2500	300			3705	1800	740	500	6 1/8	6 3/4	25 1/2	155

Notes

1. Valves set under 15 psig are not ASME code stamped.
2. Maximum A and B dimensions ± 1/16-inch.
3. API 526 eliminated 2 1/2-inch flange sizes, however ARI-Reyco will supply 2 1/2-inch flange sizes.

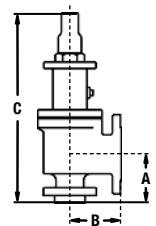

H Orifice

316 SS or WC6 Body & Bonnet;
Alloy Spring

Carbon Steel Body & Bonnet;
Alloy Spring

Carbon Steel Body & Bonnet;
Chrome Vanadium Spring

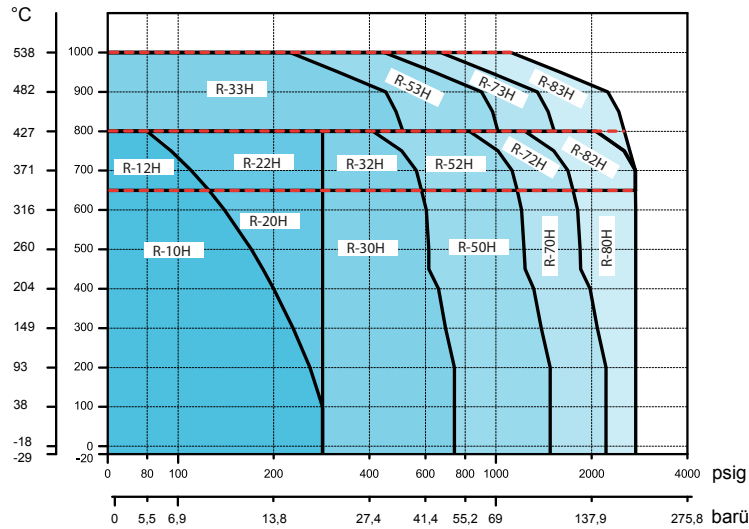

Specifications

Valve Size (inches)	Valve Model		Flange Connections ANSI Std. (RF or RTJ)		Maximum Set Pressure (psig)				Max. Back Pressure (psig @ 100°F)		Valve Dimensions (inches)			Weight (lb)
	Conv.	Bellows	Inlet	Outlet	100°F	650°F	800°F	1000°F	Conv.	Bellows	A	B	Max. C	
1.5 × 3	R-10H	RB10H	150	150	285	125			285	230	5 1/8	4 7/8	21	50
1.5 × 3	R-12H	RB12H	150	150		125	80		285	230	5 1/8	4 7/8	21	50
1.5 × 3	R-20H	RB20H	300LW	150	285	285			285	230	5 1/8	4 7/8	21	54
1.5 × 3	R-22H	RB22H	300LW	150	285	285			285	230	5 1/8	4 7/8	21	54
2 × 3	R-30H	RB30H	300	150	740	590			285	230	5 1/8	4 7/8	21	58
2 × 3	R-32H	RB32H	300	150		590	410		285	230	5 1/8	4 7/8	21	58
2 × 3	R-33H	RB33H	300	150			510	215	285	230	5 1/8	4 7/8	21	58
2 × 3	R-50H	RB50H	600	150	1480	1175			285	230	6 1/16	6 3/8	25 1/2	120
2 × 3	R-52H	RB52H	600	150		1175	825		285	230	6 1/16	6 3/8	25 1/2	120
2 × 3	R-53H	RB53H	600	150			1015	430	285	230	6 1/16	6 3/8	25 1/2	58
2 × 3	R-70H	RB70H	900	150	2220	1765			285	230	6 1/16	6 3/8	25 1/2	135
2 × 3	R-72H	RB72H	900	150		1765	1235		285	230	6 1/16	6 3/8	25 1/2	135
2 × 3	R-73H	RB73H	900	150			1525	650	285	230	6 1/16	6 3/8	25 1/2	135
2 × 3	R-80H	RB80H	1500	300	2750	2750			740	415	6 1/16	6 3/8	25 1/2	140
2 × 3	R-82H	RB82H	1500	300		2750	2055		740	415	6 1/16	6 3/8	25 1/2	140
2 × 3	R-83H	RB83H	1500	300			2540	1080	740	415	6 1/16	6 3/8	25 1/2	140

Notes

1. Valves set under 15 psig are not ASME code stamped.
2. Maximum A and B dimensions ± 1/16-inch.

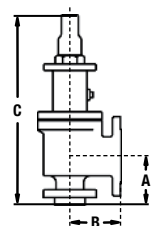

Valve Selector

J Orifice

316 SS or WC6 Body & Bonnet;
Alloy Spring

Carbon Steel Body & Bonnet;
Alloy Spring

Carbon Steel Body & Bonnet;
Chrome Vanadium Spring

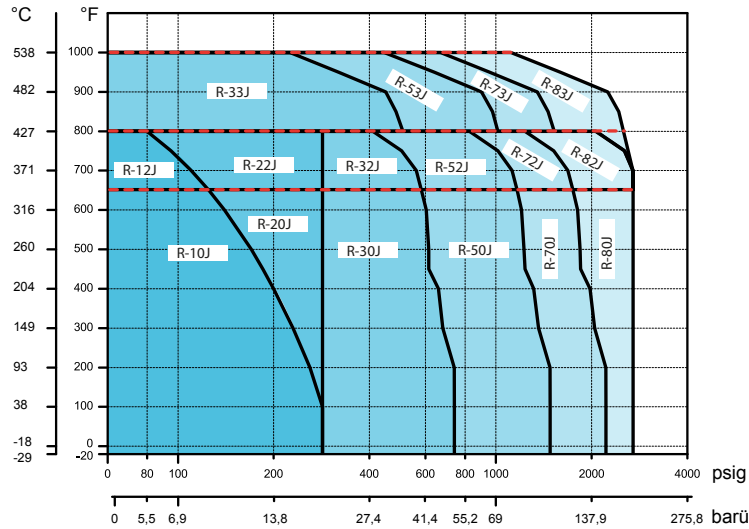

Specifications

Valve Size (inches)	Valve Model		Flange Connections ANSI Std. (RF or RTJ)		Maximum Set Pressure (psig)				Max. Back Pressure (psig @ 100°F)		Valve Dimensions (inches)			Weight (lb)
	Conv.	Bellows	Inlet	Outlet	100°F	650°F	800°F	1000°F	Conv.	Bellows	A	B	Max. C	
2 × 3	R-10J	RB10J	150	150	285	125			285	230	5 3/8	4 7/8	21 3/4	58
2 × 3	R-12J	RB12J	150	150		125	80		285	230	5 3/8	4 7/8	21 3/4	58
2 × 3	R-20J	RB20J	300LW	150	285	285			285	230	5 3/8	4 7/8	21 3/4	62
2 × 3	R-22J	RB22J	300LW	150	285	285			285	230	5 3/8	4 7/8	21 3/4	62
3 × 4	R-30J	RB30J	300	150	740	590			285	230	7 1/4	7 1/8	30 1/2	205
3 × 4	R-32J	RB32J	300	150		590	410		285	230	7 1/4	7 1/8	30 1/2	205
3 × 4	R-33J	RB33J	300	150			510	215	285	230	7 1/4	7 1/8	30 1/2	205
3 × 4	R-50J	RB50J	600	150	1480	1175			285	230	7 1/4	7 1/8	30 1/2	205
3 × 4	R-52J	RB52J	600	150		1175	825		285	230	7 1/4	7 1/8	30 1/2	205
3 × 4	R-53J	RB53J	600	150			1015	430	285	230	7 1/4	7 1/8	30 1/2	205
3 × 4	R-70J	RB70J	900	150	2220	1765			285	230	7 1/4	7 1/8	30 1/2	205
3 × 4	R-72J	RB72J	900	150		1765	1235		285	230	7 1/4	7 1/8	30 1/2	205
3 × 4	R-73J	RB73J	900	150			1525	650	285	230	7 1/4	7 1/8	30 1/2	205
3 × 4	R-80J	RB80J	1500	300	2700	2700			600	230	7 1/4	7 1/8	30 1/2	235
3 × 4	R-82J	RB82J	1500	300		2700	2055		600	230	7 1/4	7 1/8	30 1/2	235
3 × 4	R-83J	RB83J	1500	300			2540	1080	600	230	7 1/4	7 1/8	30 1/2	235

Notes

1. Valves set under 15 psig are not ASME code stamped.
2. Maximum A and B dimensions ± 1/16-inch.
3. API 526 eliminated 2 1/2-inch flange sizes, however ARI-Reyco will supply 2 1/2-inch flange sizes.

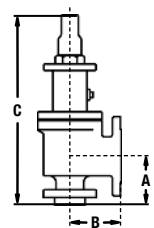

K Orifice

316 SS or WC6 Body & Bonnet;
Alloy Spring

Carbon Steel Body & Bonnet;
Alloy Spring

Carbon Steel Body & Bonnet;
Chrome Vanadium Spring

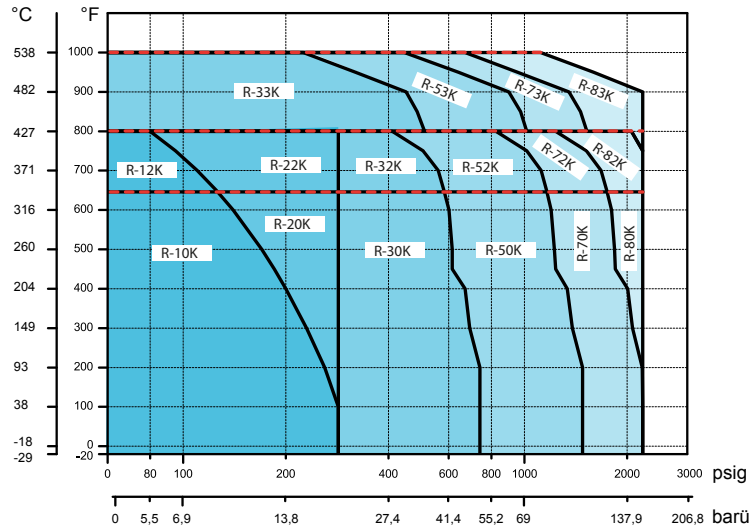

Specifications

Valve Size (inches)	Valve Model		Flange Connections ANSI Std. (RF or RTJ)		Maximum Set Pressure (psig)				Max. Back Pressure (psig @ 100°F)		Valve Dimensions (inches)			Weight (lb)
	Conv.	Bellows	Inlet	Outlet	100°F	650°F	800°F	1000°F	Conv.	Bellows	A	B	Max. C	
3 × 4	R-10K	RB10K	150	150	285	125			285	150	6 1/8	6 3/8	26 1/2	120
3 × 4	R-12K	RB12K	150	150		125	80		285	150	6 1/8	6 3/8	26 1/2	120
3 × 4	R-20K	RB20K	300LW	150	285	285			285	150	6 1/8	6 3/8	26 1/2	130
3 × 4	R-22K	RB22K	300LW	150		285	285		285	150	6 1/8	6 3/8	26 1/2	130
3 × 4	R-30K	RB30K	300	150	740	590			285	150	6 1/8	6 3/8	26 1/2	135
3 × 4	R-32K	RB32K	300	150		590	410		285	150	6 1/8	6 3/8	26 1/2	135
3 × 4	R-33K	RB33K	300	150			510	215	285	230	6 1/8	6 3/8	26 1/2	135
3 × 4	R-50K	RB50K	600	150	1480	1175			285	200	7 1/4	7 1/8	30 1/2	185
3 × 4	R-52K	RB52K	600	150		1175	825		285	200	7 1/4	7 1/8	30 1/2	185
3 × 4	R-53K	RB53K	600	150			1015	430	285	230	7 1/4	7 1/8	30 1/2	135
3 × 6	R-70K	RB70K	900	150	2220	1765			285	200	7 13/16	8 1/2	34 1/4	215
3 × 6	R-72K	RB72K	900	150		1765	1235		285	200	7 13/16	8 1/2	34 1/4	215
3 × 6	R-73K	RB73K	900	150			1525	650	285	230	7 13/16	8 1/2	34 1/4	185
3 × 6	R-80K	RB80K	1500	300	2220	2220			600	200	7 3/4	8 1/2	34 1/4	255
3 × 6	R-82K	RB82K	1500	300		2220	2055		600	200	7 3/4	8 1/2	34 1/4	255
3 × 6	R-83K	RB83K	1500	300			2220	1080	600	230	7 3/4	8 1/2	34 1/4	255

Notes

1. Valves set under 15 psig are not ASME code stamped.
2. Maximum A and B dimensions ± 1/16-inch.

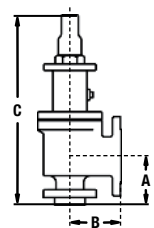

Valve Selector

L Orifice

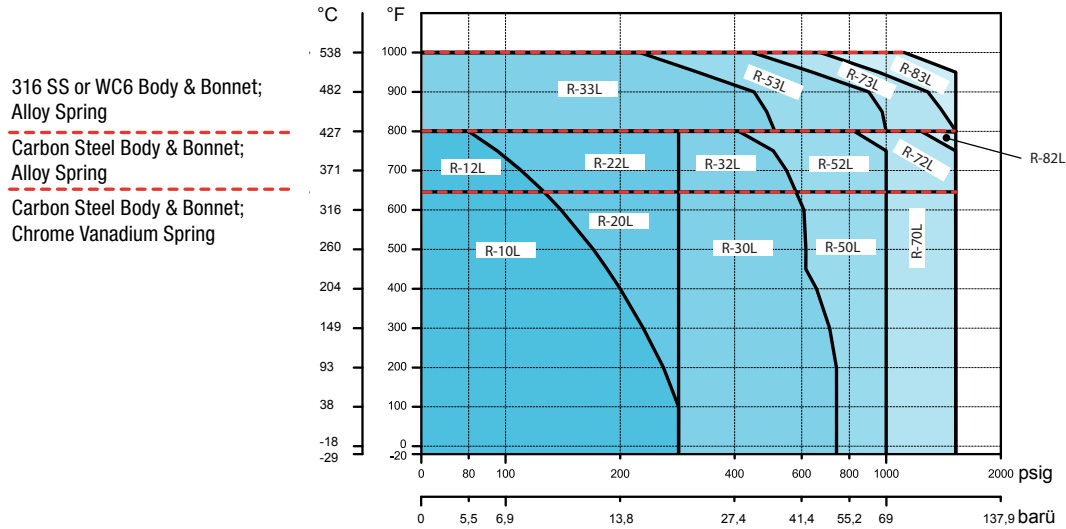

Specifications

Valve Size (inches)	Valve Model		Flange Connections ANSI Std. (RF or RTJ)		Maximum Set Pressure (psig)				Max. Back Pressure (psig @ 100°F)		Valve Dimensions (inches)			Weight (lb)
	Conv.	Bellows	Inlet	Outlet	100°F	650°F	800°F	1000°F	Conv.	Bellows	A	B	Max. C	
3 × 4	R-10L	RB10L	150	150	285	125			285	100	6 1/8	6 1/2	26 1/2	130
3 × 4	R-12L	RB12L	150	150		125	80		285	100	6 1/8	6 1/2	26 1/2	130
3 × 4	R-20L	RB20L	300LW	150	285	285			285	100	6 1/8	6 1/2	26 1/2	140
3 × 4	R-22L	RB22L	300LW	150		285	285		285	100	6 1/8	6 1/2	26 1/2	140
4 × 6	R-30L	RB30L	300	150	740	590			285	170	7 1/16	7 1/8	30 1/4	200
4 × 6	R-32L	RB32L	300	150		590	410		285	170	7 1/16	7 1/8	30 1/4	200
4 × 6	R-33L	RB33L	300	150			510	215	285	170	7 1/16	7 1/8	30 1/4	200
4 × 6	R-50L	RB50L	600	150	1000	1000			285	170	7 1/16	8	30 1/4	220
4 × 6	R-52L	RB52L	600	150		1000	825		285	170	7 1/16	8	30 1/4	220
4 × 6	R-53L	RB53L	600	150			1000	430	285	170	7 1/16	8	30 1/4	220
4 × 6	R-70L	RB70L	900	150	1500	1500			285	170	7 3/4	8 3/4	34 1/4	250
4 × 6	R-72L	RB72L	900	150		1500	1235		285	170	7 3/4	8 3/4	34 1/4	250
4 × 6	R-73L	RB73L	900	150			1500	650	285	170	7 3/4	8 3/4	34 1/4	250
4 × 6	R-80L	RB80L	1500	150	1500	1500			285	170	7 3/4	8 3/4	34 1/4	270
4 × 6	R-82L	RB82L	1500	150		1500	1500		285	170	7 3/4	8 3/4	34 1/4	270
4 × 6	R-83L	RB83L	1500	150			1500	1080	600	170	7 3/4	8 3/4	34 1/4	270

Notes

1. Valves set under 15 psig are not ASME code stamped.
2. Maximum A and B dimensions ± 1/16-inch.

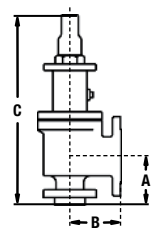

M Orifice

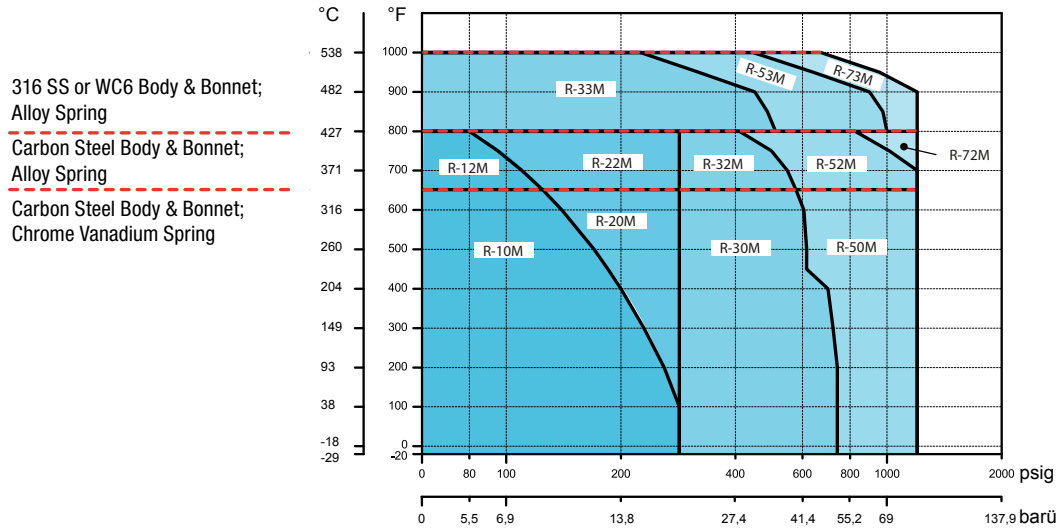

Specifications

Valve Size (inches)	Valve Model Conv.	Bellows	Flange Connections ANSI Std. (RF or RTJ)		Maximum Set Pressure (psig)				Max. Back Pressure (psig @ 100°F)		Valve Dimensions (inches)			Weight (lb)
			Inlet	Outlet	100°F	650°F	800°F	1000°F	Conv.	Bellows	A	B	Max. C	
4 × 6	R-10M	RB10M	150	150	285	125			285	80	7	7 1/4	30 1/4	190
4 × 6	R-12M	RB12M	150	150		125	80		285	80	7	7 1/4	30 1/4	190
4 × 6	R-20M	RB20M	300LW	150	285	285			285	80	7	7 1/4	30 1/4	200
4 × 6	R-22M	RB22M	300LW	150		285	285		285	80	7	7 1/4	30 1/4	200
4 × 6	R-30M	RB30M	300	150	740	590			285	160	7	7 1/4	30 1/4	205
4 × 6	R-32M	RB32M	300	150		590	410		285	160	7	7 1/4	30 1/4	205
4 × 6	R-33M	RB33M	300	150			510	215	285	160	7	7 1/4	30 1/4	205
4 × 6	R-50M	RB50M	600	150	1100	1100			285	160	7	8	33 3/4	230
4 × 6	R-52M	RB52M	600	150		1100	825		285	160	7	8	33 3/4	230
4 × 6	R-53M	RB53M	600	150			1000	430	285	160	7	8	33 3/4	230
4 × 6	R-70M	RB70M	900	150	1100	1100			285	160	7 3/4	8 3/4	34 1/4	260
4 × 6	R-72M	RB72M	900	150		1100	1100		285	160	7 3/4	8 3/4	34 1/4	260
4 × 6	R-73M	RB73M	900	150			1100	650	285	160	7 3/4	8 3/4	34 1/4	260

Notes

1. Valves set under 15 psig are not ASME code stamped.
2. Maximum A and B dimensions ± 1/16-inch.

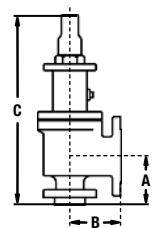

Valve Selector

N Orifice

316 SS or WC6 Body & Bonnet;
Alloy Spring

Carbon Steel Body & Bonnet;
Alloy Spring

Carbon Steel Body & Bonnet;
Chrome Vanadium Spring

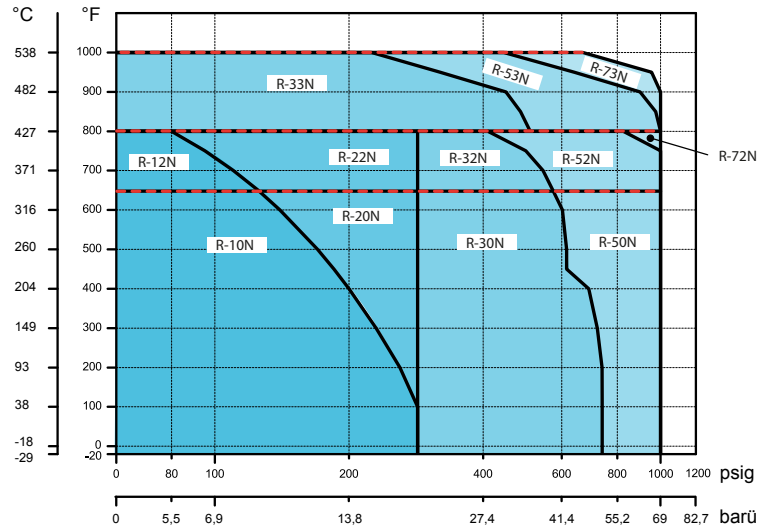

Specifications

Valve Size (inches)	Valve Model		Flange Connections ANSI Std. (RF or RTJ)		Maximum Set Pressure (psig)				Max. Back Pressure (psig @ 100°F)		Valve Dimensions (inches)			Weight (lb)
	Conv.	Bellows	Inlet	Outlet	100°F	650°F	800°F	1000°F	Conv.	Bellows	A	B	Max. C	
4 × 6	R-10N	RB10N	150	150	285	125			285	80	7 3/4	8 1/4	31 1/2	200
4 × 6	R-12N	RB12N	150	150		125	80		285	80	7 3/4	8 1/4	31 1/2	200
4 × 6	R-20N	RB20N	300LW	150	285	285			285	80	7 3/4	8 1/4	31 1/2	200
4 × 6	R-22N	RB22N	300LW	150	285	285			285	80	7 3/4	8 1/4	31 1/2	200
4 × 6	R-30N	RB30N	300	150	740	590			285	160	7 3/4	8 1/4	35	230
4 × 6	R-32N	RB32N	300	150		590	410		285	160	7 3/4	8 1/4	35	230
4 × 6	R-33N	RB33N	300	150			510	215	285	160	7 3/4	8 1/4	35	230
4 × 6	R-50N	RB50N	600	150	1000	1000			285	160	7 3/4	8 3/4	35	250
4 × 6	R-52N	RB52N	600	150		1000	825		285	160	7 3/4	8 3/4	35	250
4 × 6	R-53N	RB53N	600	150			1000	430	285	160	7 3/4	8 3/4	35	250
4 × 6	R-70N	RB70N	900	150	1000	1000			285	160	7 3/4	8 3/4	35	270
4 × 6	R-72N	RB72N	900	150		1000	1000		285	160	7 3/4	8 3/4	35	270
4 × 6	R-73N	RB73N	900	150			1000	650	285	160	7 3/4	8 3/4	35	270

Notes

1. Valves set under 15 psig are not ASME code stamped.
2. Maximum A and B dimensions ± 1/16-inch.

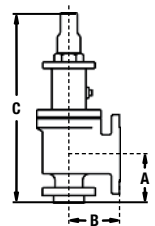

P Orifice

316 SS or WC6 Body & Bonnet;
Alloy Spring

Carbon Steel Body & Bonnet;
Alloy Spring

Carbon Steel Body & Bonnet;
Chrome Vanadium Spring

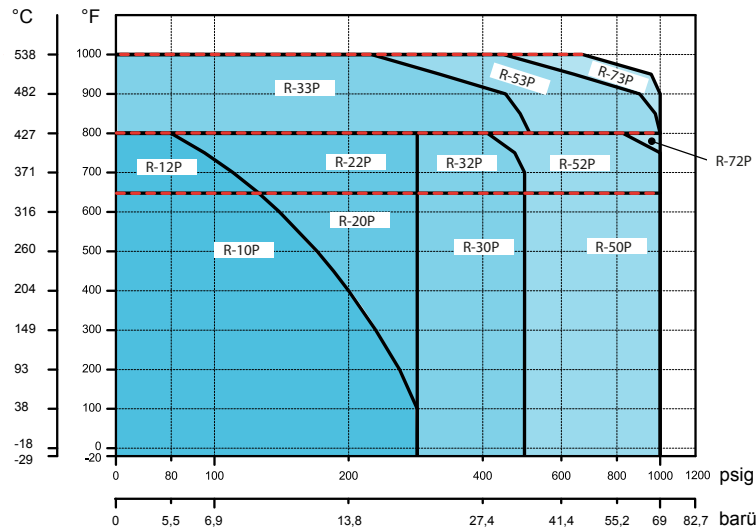

Specifications

Valve Size (inches)	Valve Model		Flange Connections ANSI Std. (RF or RTJ)		Maximum Set Pressure (psig)				Max. Back Pressure (psig @ 100°F)		Valve Dimensions (inches)			Weight (lb)
	Conv.	Bellows	Inlet	Outlet	100°F	650°F	800°F	1000°F	Conv.	Bellows	A	B	Max. C	
4 × 6	R-10P	RB10P	150	150	285	125			285	80	7 1/8	9	30 7/8	210
4 × 6	R-12P	RB12P	150	150		125	80		285	80	7 1/8	9	30 7/8	210
4 × 6	R-20P	RB20P	300LW	150	285	285			285	80	7 1/8	9	30 7/8	220
4 × 6	R-22P	RB22P	300LW	150	285	285			285	80	7 1/8	9	30 7/8	220
4 × 6	R-30P	RB30P	300	150	525	525			285	150	8 7/8	10	42 1/2	330
4 × 6	R-32P	RB32P	300	150		525	410		285	150	8 7/8	10	42 1/2	330
4 × 6	R-33P	RB33P	300	150			510	215	285	160	8 7/8	10	42 1/2	330
4 × 6	R-50P	RB50P	600	150	1000	1000			285	150	8 7/8	10	42 1/2	360
4 × 6	R-52P	RB52P	600	150		1000	825		285	150	8 7/8	10	42 1/2	360
4 × 6	R-53P	RB53P	600	150			1000	430	285	160	8 7/8	10	42 1/2	360
4 × 6	R-70P	RB70P	900	150	1000	1000			285	150	8 7/8	10	42 1/2	380
4 × 6	R-72P	RB72P	900	150		1000	1000		285	150	8 7/8	10	42 1/2	380
4 × 6	R-73P	RB73P	900	150			1000	650	285	160	8 7/8	10	42 1/2	380

Notes

- Valves set under 15 psig are not ASME code stamped.
- Maximum A and B dimensions ± 1/16-inch.

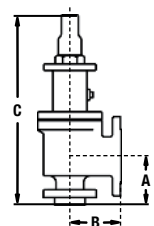

Valve Selector

Q Orifice

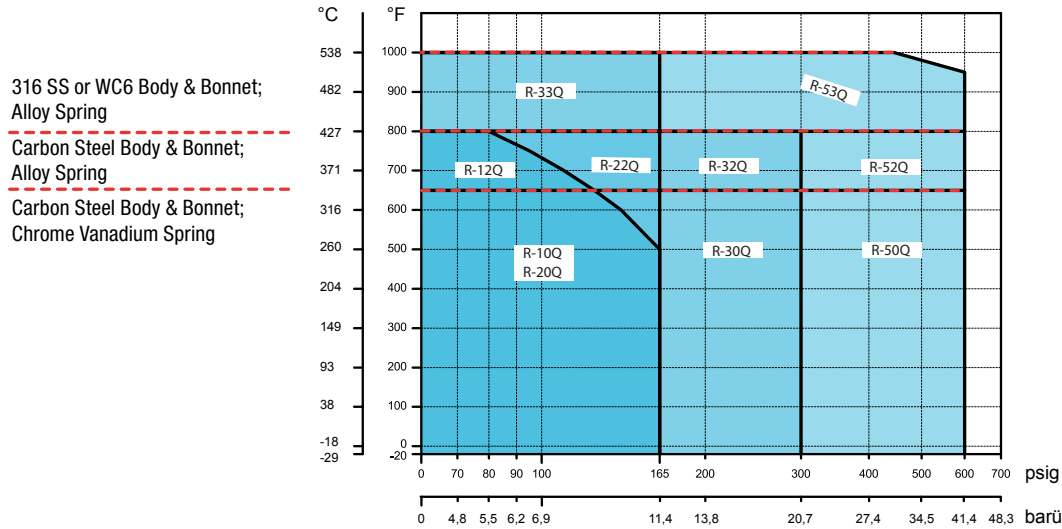

Specifications

Valve Size (inches)	Valve Model		Flange Connections ANSI Std. (RF or RTJ)		Maximum Set Pressure (psig)				Max. Back Pressure (psig @ 100°F)		Valve Dimensions (inches)			Weight (lb)
	Conv.	Bellows	Inlet	Outlet	100°F	650°F	800°F	1000°F	Conv.	Bellows	A	B	Max. C	
6 × 8	R-10Q	RB10Q	150	150	165	125			115	70	9 7/16	9 1/2	45 1/2	480
6 × 8	R-12Q	RB12Q	150	150		125	80		115	70	9 7/16	9 1/2	45 1/2	480
6 × 8	R-20Q	RB20Q	300LW	150	165	165			115	70	9 7/16	9 1/2	45 1/2	500
6 × 8	R-22Q	RB22Q	300LW	150	165	165			115	70	9 7/16	9 1/2	45 1/2	500
6 × 8	R-30Q	RB30Q	300	150	300	300			115	115	9 7/16	9 1/2	45 1/2	520
6 × 8	R-32Q	RB32Q	300	150		300	300		115	115	9 7/16	9 1/2	45 1/2	520
6 × 8	R-33Q	RB33Q	300	150			165	165	115	115	9 7/16	9 1/2	45 1/2	520
6 × 8	R-50Q	RB50Q	600	150	600	600			115	115	9 7/16	9 1/2	49 1/2	630
6 × 8	R-52Q	RB52Q	600	150		600	600		115	115	9 7/16	9 1/2	49 1/2	630
6 × 8	R-53Q	RB53Q	600	150			600	430	115	115	9 7/16	9 1/2	49 1/2	630

Notes

1. Valves set under 15 psig are not ASME code stamped.
2. Maximum A and B dimensions ± 1/8-inch.

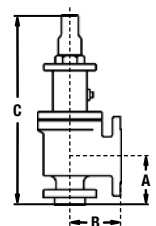

Valve Selector

R Orifice

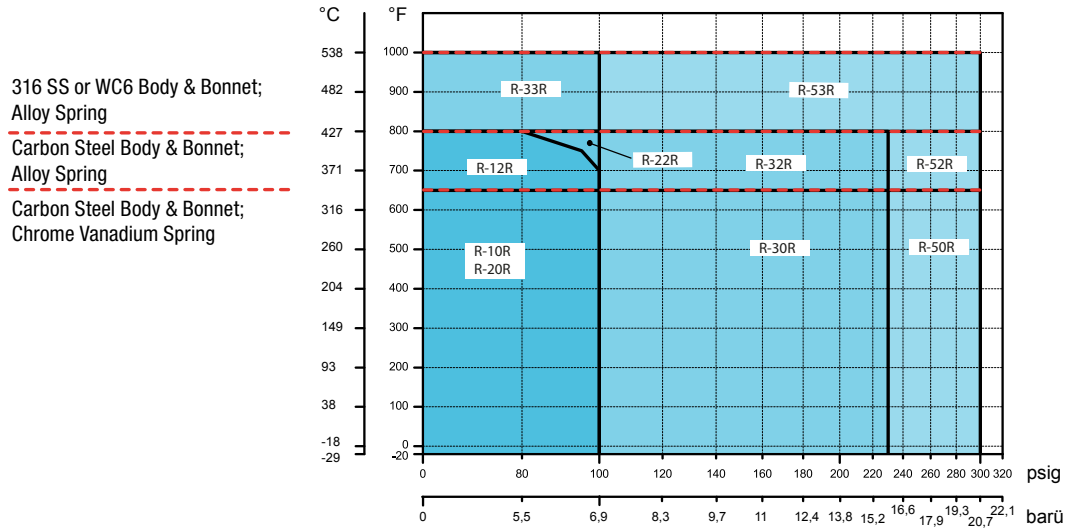

Specifications

Valve Size (inches)	Valve Model Conv.	Bellows	Flange Connections ANSI Std. (RF or RTJ)		Maximum Set Pressure (psig)				Max. Back Pressure (psig @ 100°F)		Valve Dimensions (inches)			Weight (lb)
			Inlet	Outlet	100°F	650°F	800°F	1000°F	Conv.	Bellows	A	B	Max. C	
6 × 8	R-10R	RB10R	150	150	100	100			60	60	9 7/16	9 1/2	45 1/2	500
6 × 8	R-12R	RB12R	150	150		100	80		60	60	9 7/16	9 1/2	45 1/2	500
6 × 8	R-20R	RB20R	300LW	150	100	100			60	60	9 7/16	9 1/2	45 1/2	520
6 × 8	R-22R	RB22R	300LW	150		100	100		60	60	9 7/16	9 1/2	45 1/2	520
6 × 10	R-30R	RB30R	300	150	230	230			100	100	9 7/16	10 1/2	45 1/2	620
6 × 10	R-32R	RB32R	300	150		230	230		100	100	9 7/16	10 1/2	45 1/2	620
6 × 10	R-33R	RB33R	300	150			100	100	100	100	9 7/16	10 1/2	45 1/2	620
6 × 10	R-50R	RB50R	600	150	300	300			100	100	9 7/16	10 1/2	49 1/2	660
6 × 10	R-52R	RB52R	600	150		300	300		100	100	9 7/16	10 1/2	49 1/2	660
6 × 10	R-53R	RB53R	600	150			300	300	100	100	9 7/16	10 1/2	49 1/2	660

Notes

1. Valves set under 15 psig are not ASME code stamped.
2. Maximum A and B dimensions ± 1/8-inch.

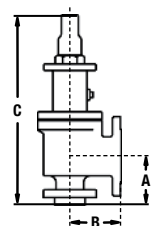

Valve Selector

T Orifice

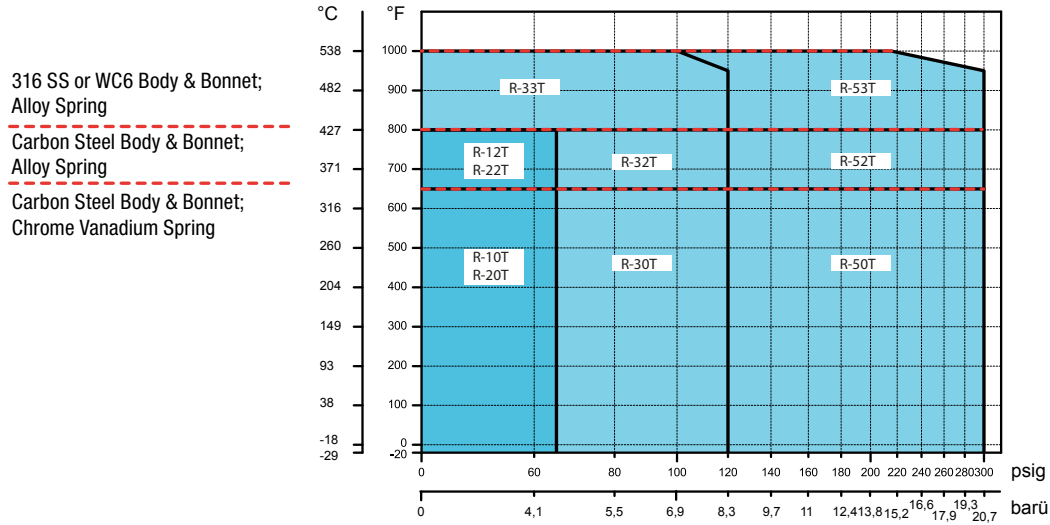

Specifications

Valve Size (inches)	Valve Model Conv.	Bellows	Flange Connections ANSI Std. (RF or RTJ)		Maximum Set Pressure (psig)				Max. Back Pressure (psig @ 100°F)		Valve Dimensions (inches)			Weight (lb)
			Inlet	Outlet	100°F	650°F	800°F	1000°F	Conv.	Bellows	A	B	Max. C	
8 × 10	R-10T	RB10T	150	150	65	65			30	30	10 7/8	11	47 3/4	670
8 × 10	R-12T	RB12T	150	150		65	65		30	30	10 7/8	11	47 3/4	670
8 × 10	R-20T	RB20T	300LW	150	65	65			30	30	10 7/8	11	47 3/4	700
8 × 10	R-22T	RB22T	300LW	150		65	65		30	30	10 7/8	11	47 3/4	700
8 × 10	R-30T	RB30T	300	150	120	120			60	60	10 7/8	11	51 1/2	790
8 × 10	R-32T	RB32T	300	150		120	120		60	60	10 7/8	11	51 1/2	790
8 × 10	R-33T	RB33T	300	150			120	100	60	60	10 7/8	11	51 1/2	790
8 × 10	R-50T	RB50T	300	150	300	300			100	100	10 7/8	11	54 3/4	830
8 × 10	R-52T	RB52T	300	150		300	300		100	100	10 7/8	11	54 3/4	830
8 × 10	R-53T	RB53T	300	150			300	215	100	100	10 7/8	11	54 3/4	830

Notes

1. Valves set under 15 psig are not ASME code stamped.
2. Maximum A and B dimensions ± 1/8-inch.

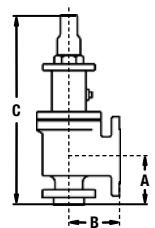

R Series Standard Trim

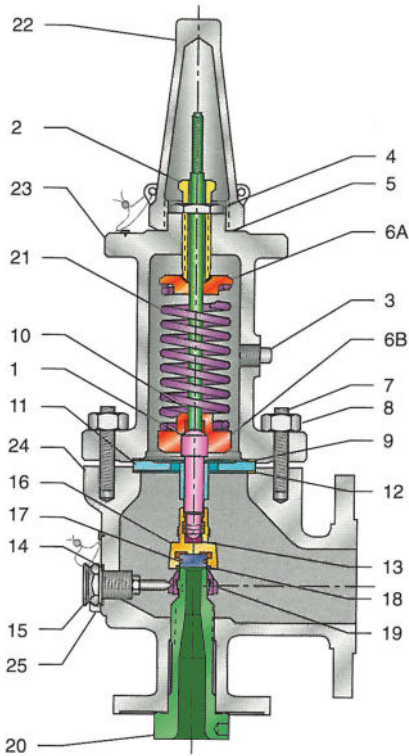

S1 Trim for Conventional Pressure Relief Valve

Part No.	Part Name	Materials
1	Point	A479 316 SS
2	Compression Screw	A479 316 SS
3	Bonnet Plug	Carbon Steel
4	Locknut	A479 316 SS
5	Cap Gasket	Soft Iron
6A	Top Spring Step	A108 CS
6B	Bottom Spring Step	A108 CS
7	Body Studs	SA193 GR. B7
8	Stud Nuts	SA194 GR. 2H
9	Bonnet Gasket	Soft Iron
10	Stem	A479 316 SS
11	Guide	A351 CF8M SS
12	Guide Gasket	Soft Iron
13	Disc Holder Insert (see note 3)	A582 416 SS
14	Ring Pin Gasket	Soft Iron
15	Ring Pin	A479 316 SS
16	Disc Holder	A351 CF8M SS
17	Disc Retainer	A313 302 SS
18	Disc	SA479 316 SS
19	Nozzle Ring	A351 CF8M SS
20	Nozzle	SA351 CF8M SS
21	Spring	Chrome Vanadium
22	Cap (see note 1)	A216 WCC
23	Bonnet	SA216 WCC
24	Body	SA216 WCC
25	Body Plug	Carbon Steel

Notes

1. Four Cap and Lift Lever styles are available: open lift lever, packed lift lever, screwed cap, and bolted cap.
2. Valves set under 15 psig [1.03 barg] are not ASME code stamped.
3. Design Revision A only.

Bill of Materials

RB Series Standard Trim

S1 Trim for Balanced Bellows Pressure Relief Valve

Part No.	Part Name	Materials
1	Point	A479 316 SS
2	Compression Screw	A479 316 SS
3	Body Plug	Carbon Steel
4	Locknut	A479 316 SS
5	Cap Gasket	Soft Iron
6A	Top Spring Step	A108 CS
6B	Bottom Spring Step	A108 CS
7	Body Studs	SA193 GR. B7
8	Stud Nuts	SA194 GR. 2H
9	Bonnet Gasket	Soft Iron
10	Stem	A479 316 SS
11	Guide	A351 CF8M SS
12	Guide Gasket	Fiber & Nitrile
13	Disc Holder Insert (see note 4)	A582 416 SS
14	Ring Pin Gasket	Soft Iron
15	Ring Pin	A479 316 SS
16	Disc Holder	A351 CF8M SS
17	Disc Retainer	A313 302 SS
18	Disc	SA479 316 SS
19	Nozzle Ring	A351 CF8M SS
20	Nozzle	SA351 CF8M SS
21	Spring	Chrome Vanadium
22	Cap (see note 1)	A216 WCC
23	Bonnet	SA216 WCC
24	Body	SA216 WCC
26	Bellows	Inconel® 625 LCF (with A479 316 SS Nut & Flange)
27	Bellows Spacer (see note 2)	A479 316 SS
28	Bellows Spacer Gasket (see note 2)	Soft Iron
29	Bellows Nut Gasket	Fiber & Nitrile
30	Lift Restrictor (see note 2) D & E Orifices	A479 316 SS

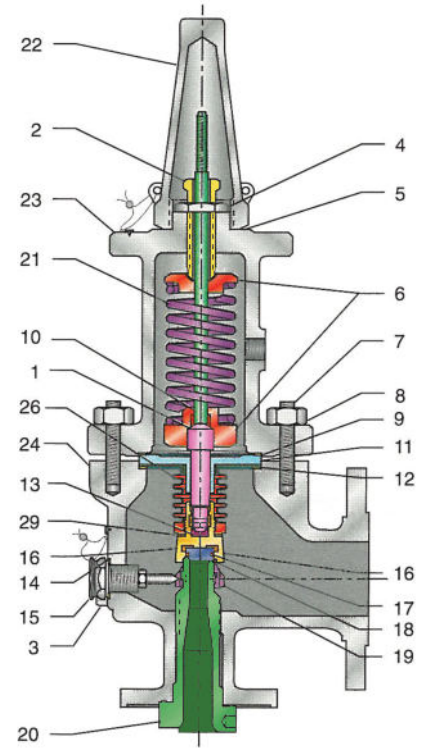

Notes

1. Four Cap and Lift Lever styles are available: open lift lever, packed lift lever, screwed cap, and bolted cap.
2. Bellows Spacer, Bellows Spacer Gasket, and Lift Restrictor are not shown, and are only present in D & E Orifices.
3. Valves set under 15 psig [1.03 barg] are not ASME code stamped.
4. Design Revision A only.

Bill of Materials

Carbon Steel and Stainless Steel Trim

Carbon Steel and Stainless Steel Trim for All Models

Part Name	S1	S2	S3	S4	S5
	Standard Materials -20°F to +800°F	Internal Parts Except Spring & Steps -20°F to +800°F	Complete Valve Except Spring & Steps -20°F to +1000°F	Entire Valve -20°F to +1000°F	All Parts Below Bellows -20°F to +800°F
Stem	A479 316 SS	A479 316 SS	A479 316 SS	A479 316 SS	A479 316 SS
Point (see note 1)	A479 316 SS	A479 316 SS	A479 316 SS	A479 316 SS	A479 316 SS
Compression Screw	A479 316 SS	A479 316 SS	A479 316 SS	A479 316 SS	A479 316 SS
Bonnet Plug (see note 2)	Carbon Steel	Carbon Steel	Stainless Steel	Stainless Steel	N/A
Locknut	A479 316 SS	A479 316 SS	A479 316 SS	A479 316 SS	A479 316 SS
Cap Gasket	Soft Iron	Monel®	Monel®	Monel®	Soft Iron
Spring Steps	A108 CS	A108 CS	A108 CS	A479 316 SS	A108 CS
Body Studs	SA193 B7	SA193 B7	SA320 B8M	SA320 B8M	SA193 B7
Stud Nuts	SA194 2H	SA194 2H	SA194 8M	SA194 8M	SA194 2H
Top Bellows Gasket	Fiber and Nitrile	Fiber and Nitrile	Fiber and Nitrile	Fiber and Nitrile	Fiber and Nitrile
Guide (see note 3)	A351 CF8M SS	A351 CF8M SS	A351 CF8M SS	A351 CF8M SS	A351 CF8M SS
Bottom Bellows Gasket	Fiber and Nitrile	Fiber and Nitrile	Fiber and Nitrile	Fiber and Nitrile	Fiber and Nitrile
Holder Insert (see note 6)	A582 416 SS	A582 416 SS	A582 416 SS	A582 416 SS	A582 416 SS
Ring Pin Gasket	Soft Iron	Monel®	Monel®	Monel®	Monel®
Ring Pin	A479 316 SS	A479 316 SS	A479 316 SS	A479 316 SS	A479 316 SS
Disc Holder	A351 CF8M SS	A351 CF8M SS	A351 CF8M SS	A351 CF8M SS	A351 CF8M SS
Disc Retaining Ring	A313 302 SS	A313 302 SS	A313 302 SS	A313 302 SS	A313 302 SS
Disc	SA479 316 SS	SA479 316 SS	SA479 316 SS	SA479 316 SS	SA479 316 SS
Adjusting Ring	A351 CF8M SS	A351 CF8M SS	A351 CF8M SS	A351 CF8M SS	A351 CF8M SS
Nozzle	SA351 CF8M SS	SA351 CF8M SS	SA351 CF8M SS	SA351 CF8M SS	SA351 CF8M SS
Spring (see note 4)	Chrome Vanadium	Chrome Vanadium	Chrome Vanadium	A313 316 SS	Chrome Vanadium
Cap	A216 WCC	A216 WCC	A351 CF8M SS	A351 CF8M SS	A216 WCC
Bonnet	SA216 WCC	SA216 WCC	SA351 CF8M SS	SA351 CF8M SS	SA216 WCC
Body	SA216 WCC	SA216 WCC	SA351 CF8M SS	SA351 CF8M SS	SA351 CF8M SS
Body Plug	Carbon Steel	Carbon Steel	Stainless Steel	Stainless Steel	Stainless Steel
Bellows	Inconel® 625 LCF	Inconel® 625 LCF	Inconel® 625 LCF	Inconel® 625 LCF	Inconel® 625 LCF
Bellows Flange	A240 316 SS	A240 316 SS	A240 316 SS	A240 316 SS	A240 316 SS
Bellows Nut	A479 316 SS	A479 316 SS	A479 316 SS	A479 316 SS	A479 316 SS
Bellows Spacer (see note 5)	A479 316 SS	A479 316 SS	A479 316 SS	A479 316 SS	A479 316 SS
Body Guide Gasket	Soft Iron	Monel®	Monel®	Monel®	Soft Iron
Guide Bonnet Gasket	Soft Iron	Monel®	Monel®	Monel®	Soft Iron
Lift Restrictor (see note 5)	A479 316 SS	A479 316 SS	A479 316 SS	A479 316 SS	A479 316 SS

Notes

1. Not applicable to Orifice D & E for RB/RBO.
2. Not applicable to RB/RBO Series.
3. Guide material for steam service is Monel® A494 M-35-2 for temperature range Code 1.
4. Inconel® X-750 or alloy spring material may be required for some pressures, sizes, or temperatures.
5. Applicable only to Orifice D & E for RB/RBO.
6. Design Revision A only.

Bill of Materials

Monel® Trim

Monel® Trim for Conventional for All Models

Part Name	M1 Nozzle and Disc -20°F to +800°F	M2 Internal Parts Except Spring & Steps -20°F to +800°F	M3 Complete Valve Except Spring & Steps -20°F to +900°F	M4 Entire Valve -20°F to +450°F	M5 All Parts Below Bellows -20°F to +800°F
Stem	A479 316 SS	B164 UNS N04400	B164 UNS N04400	B164 UNS N04400	A479 316 SS
Point (see note 1)	A479 316 SS	B164 UNS N04400	B164 UNS N04400	B164 UNS N04400	A479 316 SS
Compression Screw	A479 316 SS	B164 UNS N04400	B164 UNS N04400	B164 UNS N04400	A479 316 SS
Bonnet Plug (see note 2)	Carbon Steel	Carbon Steel	B164 UNS N04400	B164 UNS N04400	N/A
Locknut	A479 316 SS	B164 UNS N04400	B164 UNS N04400	B164 UNS N04400	A479 316 SS
Cap Gasket	Soft Iron	Monel®	Monel®	Monel®	Soft Iron
Spring Steps	A108 CS	A108 CS	A108 CS	B164 UNS N04400	A108 CS
Body Studs	SA193 B7	SA193 B7	SF468 UNS N04400	SF468 UNS N04400	SA193 B7
Stud Nuts	SA194 2H	SA194 2H	SF467 UNS N04400	SF467 UNS N04400	SA194 2H
Top Bellows Gasket	Fiber and Nitrile	Fiber and Nitrile	Fiber and Nitrile	Fiber and Nitrile	Fiber and Nitrile
Guide (see note 3)	A351 CF8M SS	A494 M-35-2	A494 M-35-2	A494 M-35-2	A351 CF8M SS
Bottom Bellows Gasket	Fiber and Nitrile	Fiber and Nitrile	Fiber and Nitrile	Fiber and Nitrile	Fiber and Nitrile
Holder Insert (see note 7)	A582 416 SS	B164 UNS N04400	B164 UNS N04400	B164 UNS N04400	A582 416 SS
Ring Pin Gasket	Soft Iron	Monel®	Monel®	Monel®	Monel®
Ring Pin	A479 316 SS	B164 UNS N04400	B164 UNS N04400	B164 UNS N04400	B164 UNS N04400
Disc Holder	A351 CF8M SS	A494 M-35-2	A494 M-35-2	A494 M-35-2	A494 M-35-2
Disc Retaining Ring	A313 302 SS	Monel®	Monel®	Monel®	Monel®
Disc	SB164 UNS N04400	SB164 UNS N04400	SB164 UNS N04400	SB164 UNS N04400	SB164 UNS N04400
Adjusting Ring	A351 CF8M SS	A494 M-35-2	A494 M-35-2	A494 M-35-2	A494 M-35-2
Nozzle	SA494 M-35-2	SA494 M-35-2	SA494 M-35-2	SA494 M-35-2	SA494 M-35-2
Spring (see note 4)	Chrome Vanadium	Chrome Vanadium	Chrome Vanadium	Inconel® X-750	Chrome Vanadium
Cap	A216 WCC	A216 WCC	A494 M-35-2	A494 M-35-2	A216 WCC
Bonnet (see note 6)	SA216 WCC	SA216 WCC	SA494 M-35-2	SA494 M-35-2	SA216 WCC
Body (see note 6)	SA216 WCC	SA216 WCC	SA494 M-35-2	SA494 M-35-2	SA494 M-35-2
Body Plug	Carbon Steel	Carbon Steel	B164 UNS N04400	B164 UNS N04400	B164 UNS N04400
Bellows	Inconel® 625 LCF	B164 UNS N04400	B164 UNS N04400	B164 UNS N04400	B164 UNS N04400
Bellows Flange	A240 316 SS	B164 UNS N04400	B164 UNS N04400	B164 UNS N04400	B164 UNS N04400
Bellows Nut	A479 316 SS	B164 UNS N04400	B164 UNS N04400	B164 UNS N04400	B164 UNS N04400
Bellows Spacer (see note 5)	A479 316 SS	A479 316 SS	B164 UNS N04400	B164 UNS N04400	B164 UNS N04400
Body Guide Gasket	Soft Iron	Monel®	Monel®	Monel®	Soft Iron
Guide Bonnet Gasket	Soft Iron	Monel®	Monel®	Monel®	Soft Iron
Lift Restrictor (see note 5)	A479 316 SS	B164 UNS N04400	B164 UNS N04400	B164 UNS N04400	B164 UNS N04400

Notes

1. Not applicable to Orifice D & E for RB/RBO.
2. Not applicable to RB/RBO Series.
3. Guide material for steam service is Monel® A494 M-35-2 for temperature range Code 1.
4. Alloy spring may be required for some temperature ranges.
5. Applicable only for Orifices D & E.
6. High temperature (above 800°F) material is SA217 WC6 or SA351 CF8M for material options M1 and M2.
7. Design Revision A only.

Bill of Materials

Hastelloy® C Trim

Hastelloy® C Trim for All Models

Part Name	H1 Nozzle and Disc -20°F to +800°F	H2 Internal Parts Except Spring & Steps -20°F to +800°F	H3 Complete Valve Except Spring & Steps -20°F to +1000°F	H4 Entire Valve -20°F to +700°F	H5 All Parts Below Bellows -20°F to +800°F
Stem	A479 316 SS	B574 UNS N10276	B574 UNS N10276	B574 UNS N10276	A479 316 SS
Point (see note 1)	A479 316 SS	B574 UNS N10276	B574 UNS N10276	B574 UNS N10276	A479 316 SS
Compression Screw	A479 316 SS	B574 UNS N10276	B574 UNS N10276	B574 UNS N10276	A479 316 SS
Bonnet Plug (see note 2)	Carbon Steel	Carbon Steel	B574 UNS N10276	B574 UNS N10276	N/A
Locknut	A479 316 SS	B574 UNS N10276	B574 UNS N10276	B574 UNS N10276	A479 316 SS
Cap Gasket	Soft Iron	Monel®	Monel®	Monel®	Soft Iron
Spring Steps	A108 CS	A108 CS	A108 CS	B574 UNS N10276	A108 CS
Body Studs	SA193 B7	SA193 B7	SF468 UNS N04400	SF468 UNS N04400	SA193 B7
Stud Nuts	SA194 2H	SA194 2H	SF467 UNS N04400	SF467 UNS N04400	SA194 2H
Top Bellows Gasket	Fiber and Nitrile	Fiber and Nitrile	Fiber and Nitrile	Fiber and Nitrile	Fiber and Nitrile
Guide (see note 3)	A351 CF8M SS	A494 CW-12MW	A494 CW-12MW	A494 CW-12MW	A351 CF8M SS
Bottom Bellows Gasket	Fiber and Nitrile	Fiber and Nitrile	Fiber and Nitrile	Fiber and Nitrile	Fiber and Nitrile
Holder Insert (see note 7)	A582 416 SS	B574 UNS N10276	B574 UNS N10276	B574 UNS N10276	A582 416 SS
Ring Pin Gasket	Soft Iron	Monel®	Monel®	Monel®	Monel®
Ring Pin	A479 316 SS	B574 UNS N10276	B574 UNS N10276	B574 UNS N10276	B574 UNS N10276
Disc Holder	A351 CF8M SS	A494 CW-12MW	A494 CW-12MW	A494 CW-12MW	A494 CW-12MW
Disc Retaining Ring	A313 302 SS	Hastelloy® C	Hastelloy® C	Hastelloy® C	Hastelloy® C
Disc	SB574 UNS N10276	SB574 UNS N10276	SB574 UNS N10276	SB574 UNS N10276	SB574 UNS N10276
Adjusting Ring	A351 CF8M SS	A494 CW-12MW	A494 CW-12MW	A494 CW-12MW	A494 CW-12MW
Nozzle	SA494 CW-12MW	SA494 CW-12MW	SA494 CW-12MW	SA494 CW-12MW	SA494 CW-12MW
Spring (see note 4)	Chrome Vanadium	Chrome Vanadium	Chrome Vanadium	B574 UNS N10276	Chrome Vanadium
Cap	A216 WCC	A216 WCC	A494 CW-12MW	A494 CW-12MW	A216 WCC
Bonnet (see note 6)	SA216 WCC	SA216 WCC	SA494 CW-12MW	SA494 CW-12MW	SA216 WCC
Body (see note 6)	SA216 WCC	SA216 WCC	SA494 CW-12MW	SA494 CW-12MW	SA494 CW-12MW
Body Plug	Carbon Steel	Carbon Steel	B574 UNS N10276	B574 UNS N10276	B574 UNS N10276
Bellows	Inconel® 625 LCF	B574 UNS N10276	B574 UNS N10276	B574 UNS N10276	B574 UNS N10276
Bellows Flange	A240 316 SS	B574 UNS N10276	B574 UNS N10276	B574 UNS N10276	B574 UNS N10276
Bellows Nut	A479 316 SS	B574 UNS N10276	B574 UNS N10276	B574 UNS N10276	B574 UNS N10276
Bellows Spacer (see note 5)	A479 316 SS	A479 316 SS	B574 UNS N10276	B574 UNS N10276	B574 UNS N10276
Body Guide Gasket	Soft Iron	Monel®	Monel®	Monel®	Soft Iron
Guide Bonnet Gasket	Soft Iron	Monel®	Monel®	Monel®	Soft Iron
Lift Restrictor (see note 5)	A479 316 SS	B574 UNS N10276	B574 UNS N10276	B574 UNS N10276	B574 UNS N10276

Notes

1. Not applicable to Orifice D & E for RB/RBO.
2. Not applicable to RB/RBO Series.
3. Guide material for steam service is Monel® A494 M-35-2 for temperature range Code 1.
4. Alloy spring may be required for some temperature ranges.
5. Applicable only for Orifices D & E.
6. High temperature (above 800°F) material is SA217 WC6 or SA351 CF8M for material options H1 and H2.
7. Design Revision A only.

Bill of Materials

Duplex Trim

Duplex Trim for All Models

Part Name	D1	D2	D3	D4	D5
	Standard Materials -20°F to +800°F	Internal Parts Except Spring & Steps -20°F to +800°F	Complete Valve Except Spring & Steps -20°F to +1000°F	Entire Valve -20°F to +1000°F	All Parts Below Bellows -20°F to +800°F
Stem	A479 316 SS	A479 UNS S32205	A479 UNS S32205	A479 UNS S32205	A479 316 SS
Point (see note 1)	A479 316 SS	A479 UNS S32205	A479 UNS S32205	A479 UNS S32205	A479 316 SS
Compression Screw	A479 316 SS	A479 UNS S32205	A479 UNS S32205	A479 UNS S32205	A479 316 SS
Bonnet Plug (see note 2)	Carbon Steel	Carbon Steel	Duplex 2205	Duplex 2205	N/A
Locknut	A479 316 SS	A479 UNS S32205	A479 UNS S32205	A479 UNS S32205	A479 316 SS
Cap Gasket	Soft Iron	Monel®	Monel®	Monel®	Soft Iron
Spring Steps	A108 CS	A108 CS	A108 CS	A479 UNS S32205	A108 CS
Body Studs	SA193 B7	SA193 B7	SA320 B8M	SA320 B8M	SA193 B7
Stud Nuts	SA194 2H	SA194 2H	SA194 8M	SA194 8M	SA194 2H
Top Bellows Gasket	Fiber and Nitrile	Fiber and Nitrile	Fiber and Nitrile	Fiber and Nitrile	Fiber and Nitrile
Guide	A351 CF8M SS	A995 CD3MN	A995 CD3MN	A995 CD3MN	A351 CF8M SS
Bottom Bellows Gasket	Fiber and Nitrile	Fiber and Nitrile	Fiber and Nitrile	Fiber and Nitrile	Fiber and Nitrile
Holder Insert (see note 5)	A582 416 SS	A479 UNS S32205	A479 UNS S32205	A479 UNS S32205	A582 416 SS
Ring Pin Gasket	Soft Iron	Monel®	Monel®	Monel®	Soft Iron
Ring Pin	A479 316 SS	A479 UNS S32205	A479 UNS S32205	A479 UNS S32205	A479 UNS S32205
Disc Holder	A351 CF8M SS	A995 CD3MN	A995 CD3MN	A995 CD3MN	A995 CD3MN
Disc Retaining Ring	A313 302 SS	Duplex 2205	Duplex 2205	Duplex 2205	Duplex 2205
Disc	SA479 UNS S32205	SA479 UNS S32205	SA479 UNS S32205	SA479 UNS S32205	SA479 UNS S32205
Adjusting Ring	A351 CF8M SS	A995 CD3MN	A995 CD3MN	A995 CD3MN	A995 CD3MN
Nozzle	SA995 CD3MN	SA995 CD3MN	SA995 CD3MN	SA995 CD3MN	SA995 CD3MN
Spring (see note 3)	Chrome Vanadium	Inconel® X-750	Chrome Vanadium	Inconel® X-750	Chrome Vanadium
Cap	A216 WCC	A216 WCC	A995 CD3MN	A995 CD3MN	A216 WCC
Bonnet	SA216 WCC	SA216 WCC	SA995 CD3MN	SA995 CD3MN	SA216 WCC
Body	SA216 WCC	SA216 WCC	SA995 CD3MN	SA995 CD3MN	SA995 CD3MN
Body Plug	Carbon Steel	Carbon Steel	Duplex 2205	Duplex 2205	Duplex 2205
Bellows	Inconel® 625 LCF	A479 UNS S32205	A479 UNS S32205	A479 UNS S32205	A479 UNS S32205
Bellows Flange	A240 316 SS	A479 UNS S32205	A479 UNS S32205	A479 UNS S32205	A479 UNS S32205
Bellows Nut	A479 316 SS	A479 UNS S32205	A479 UNS S32205	A479 UNS S32205	A479 UNS S32205
Bellows Spacer	A479 316 SS	A479 316 SS	A479 UNS S32205	A479 UNS S32205	A479 UNS S32205
Body Guide Gasket	Soft Iron	Monel®	Monel®	Monel®	Soft Iron
Guide Bonnet Gasket	Soft Iron	Monel®	Monel®	Monel®	Soft Iron
Lift Restrictor (see note 4)	A479 316 SS	A479 UNS S32205	A479 UNS S32205	A479 UNS S32205	A479 UNS S32205

Notes

1. Not applicable to Orifice D & E for RB/RBO.
2. Not applicable to RB/RBO Series.
3. Alloy spring may be required for some temperature ranges.
4. Applicable only for Orifices D & E.
5. Design Revision A only.

Bill of Materials

Alloy 20 Trim

Alloy 20 Trim for All Models

Part Name	A1	A2	A3	A4	A5
	Standard Materials -20°F to +300°F	Internal Parts Except Spring & Steps -20°F to +300°F	Complete Valve Except Spring & Steps -20°F to +300°F	Entire Valve -20°F to +300°F	All Parts Below Bellows -20°F to +300°F
Stem	A479 316 SS	B473 UNS N08020	B473 UNS N08020	B473 UNS N08020	A479 316 SS
Point (see note 1)	A479 316 SS	B473 UNS N08020	B473 UNS N08020	B473 UNS N08020	A479 316 SS
Compression Screw	A479 316 SS	B473 UNS N08020	B473 UNS N08020	B473 UNS N08020	A479 316 SS
Bonnet Plug (see note 2)	Carbon Steel	Carbon Steel	B473 UNS N08020	B473 UNS N08020	N/A
Locknut	A479 316 SS	B473 UNS N08020	B473 UNS N08020	B473 UNS N08020	A479 316 SS
Cap Gasket	Soft Iron	Monel®	Monel®	Monel®	Soft Iron
Spring Steps	A108 CS	A108 CS	A108 CS	B473 UNS N08020	A108 CS
Body Studs	SA193 B7	SA193 B7	Alloy 20	Alloy 20	SA193 B7
Stud Nuts	SA194 2H	SA194 2H	Alloy 20	Alloy 20	SA194 2H
Top Bellows Gasket	Fiber and Nitrile	Fiber and Nitrile	Fiber and Nitrile	Fiber and Nitrile	Fiber and Nitrile
Guide	A351 CF8M SS	A351 CN7M	A351 CN7M	A351 CN7M	A351 CF8M SS
Bottom Bellows Gasket	Fiber and Nitrile	Fiber and Nitrile	Fiber and Nitrile	Fiber and Nitrile	Fiber and Nitrile
Holder Insert (see note 5)	A582 416 SS	B473 UNS N08020	B473 UNS N08020	B473 UNS N08020	A582 416 SS
Ring Pin Gasket	Soft Iron	Monel®	Monel®	Monel®	Soft Iron
Ring Pin	A479 316 SS	B473 UNS N08020	B473 UNS N08020	B473 UNS N08020	B473 UNS N08020
Disc Holder	A351 CF8M SS	A351 CN7M	A351 CN7M	A351 CN7M	A351 CN7M
Disc Retaining Ring	A313 302 SS	Alloy 20	Alloy 20	Alloy 20	Alloy 20
Disc	SB473 UNS N08020	SB473 UNS N08020	SB473 UNS N08020	SB473 UNS N08020	SB473 UNS N08020
Adjusting Ring	A351 CF8M SS	A351 CN7M	A351 CN7M	A351 CN7M	A351 CN7M
Nozzle	SA351 CN7M	SA351 CN7M	SA351 CN7M	SA351 CN7M	SA351 CN7M
Spring (see note 3)	Chrome Vanadium	Alloy 20	Chrome Vanadium	Alloy 20	Chrome Vanadium
Cap	A216 WCC	A216 WCC	A351 CN7M	A351 CN7M	A216 WCC
Bonnet	SA216 WCC	SA216 WCC	SA351 CN7M	SA351 CN7M	SA216 WCC
Body	SA216 WCC	SA216 WCC	SA351 CN7M	SA351 CN7M	SA351 CN7M
Body Plug	Carbon Steel	Carbon Steel	B473 UNS N08020	B473 UNS N08020	B473 UNS N08020
Bellows	Inconel® 625 LCF	B473 UNS N08020	B473 UNS N08020	B473 UNS N08020	B473 UNS N08020
Bellows Flange	A240 316 SS	B473 UNS N08020	B473 UNS N08020	B473 UNS N08020	B473 UNS N08020
Bellows Nut	A479 316 SS	B473 UNS N08020	B473 UNS N08020	B473 UNS N08020	B473 UNS N08020
Bellows Spacer	A479 316 SS	A479 316 SS	B473 UNS N08020	B473 UNS N08020	B473 UNS N08020
Body Guide Gasket	Soft Iron	Monel®	Monel®	Monel®	Soft Iron
Guide Bonnet Gasket	Soft Iron	Monel®	Monel®	Monel®	Soft Iron
Lift Restrictor (see note 4)	A479 316 SS	B473 UNS N08020	B473 UNS N08020	B473 UNS N08020	B473 UNS N08020

Notes

1. Not applicable to Orifice D & E for RB/RBO.
2. Not applicable to RB/RBO Series.
3. Alloy spring may be required for some temperature ranges.
4. Applicable only for Orifices D & E.
5. Design Revision A only.

Bill of Materials

Low Temperature Trim

Low Temperature Trim for All Models

Part Name	L1	L2	L3	LC
	Low Temperature	Low Temperature	Low Temperature	Low Temperature
	-75°F to -21°F	-150°F to -76°F	-400°F to -151°F	-50°F to -21°F
Stem (see note 1)	A479 316 SS	A479 316 SS	A479 316 SS	A479 316 SS
Point	A479 316 SS	A479 316 SS	A479 316 SS	A479 316 SS
Compression Screw	A479 316 SS	A479 316 SS	A479 316 SS	A479 316 SS
Bonnet Plug (see note 2)	Carbon Steel	A479 316 SS	A479 316 SS	Carbon Steel
Locknut	A479 316 SS	A479 316 SS	A479 316 SS	A479 316 SS
Cap Gasket	Monel®	Monel®	Monel®	Monel®
Spring Steps	A108 CS	A479 316 SS	A479 316 SS	A108 CS
Body Studs	SA320 B8M	SA320 B8M	SA320 B8M	SA320 B8M
Stud Nuts	SA194 8M	SA194 8M	SA194 8M	SA194 8M
Top Bellows Gasket	Monel®	Monel®	Monel®	Monel®
Guide	A351 CF8M SS	A351 CF8M SS	A351 CF8M SS	A351 CF8M SS
Bottom Bellows Gasket	Monel®	Monel®	Monel®	Monel®
Holder Insert (see note 4)	A479 316 SS	A479 316 SS	A479 316 SS	A479 316 SS
Ring Pin Gasket	Monel®	Monel®	Monel®	Monel®
Ring Pin	A479 316 SS	A479 316 SS	A479 316 SS	A479 316 SS
Disc Holder	A351 CF8M SS	A351 CF8M SS	A351 CF8M SS	A351 CF8M SS
Disc Retaining Ring	A313 302 SS	A313 302 SS	A313 302 SS	A313 302 SS
Disc	SA479 316 SS	SA479 316 SS	SA479 316 SS	SA479 316 SS
Adjusting Ring	A351 CF8M SS	A351 CF8M SS	A351 CF8M SS	A351 CF8M SS
Nozzle	SA351 CF8M SS	SA351 CF8M SS	SA351 CF8M SS	SA351 CF8M SS
Spring	Chrome Vanadium	A313 316 SS	A313 316 SS	Chrome Vanadium
Cap	A216 WCC	A351 CF8M SS	A351 CF8M SS	SA352 LCC
Bonnet	SA216 WCC	SA351 CF8M SS	SA351 CF8M SS	SA352 LCC
Body	SA351 CF8M SS	SA351 CF8M SS	SA351 CF8M SS	SA352 LCC
Body Plug	A479 316 SS	A479 316 SS	A479 316 SS	A479 316 SS
Bellows	Inconel® 625 LCF	Inconel® 625 LCF	316L SS	Inconel® 625 LCF
Bellows Flange	A240 316 SS	A240 316 SS	316L SS	A240 316 SS
Bellows Nut	A479 316 SS	A479 316 SS	316L SS	A479 316 SS
Bellows Spacer (see note 3)	A479 316 SS	A479 316 SS	A479 316 SS	A479 316 SS
Body Guide Gasket	Monel®	Monel®	Monel®	Monel®
Guide Bonnet Gasket	Monel®	Monel®	Monel®	Monel®
Lift Restrictor (see note 3)	A479 316 SS	A479 316 SS	A479 316 SS	A479 316 SS

Notes

1. Not applicable to Orifice D & E for RB/RBO.
2. Not applicable to RB/RBO Series.
3. Applicable only to Orifice D & E for RB/RBO.
4. Design Revision A only.

Bill of Materials

NACE and High Temperature Trim

NACE Trim and High Temperature Trim for All Models

Part Name	SG Sour Gas NACE MR-01-75 -20°F to +800°F	SS Sour Gas NACE MR-01-75 -20°F to +800°F	W1 High Temperature -20°F to +1000°F	W2 High Temperature -20°F to +1000°F
Stem (see note 1)	A479 316 SS	A479 316 SS	A479 316 SS	A479 316 SS
Point	A479 316 SS	A479 316 SS	A479 316 SS	A479 316 SS
Compression Screw	A479 316 SS	A479 316 SS	A479 316 SS	A479 316 SS
Bonnet Plug (see note 2)	Carbon Steel	A479 316 SS	Carbon Steel	316 SS
Locknut	A479 316 SS	A479 316 SS	A479 316 SS	A479 316 SS
Cap Gasket	Soft Iron	316 SS	Monel®	Monel®
Spring Steps	A479 316 SS	A479 316 SS	A108 CS	A108 CS
Body Studs	SA193 B7	SA320 B8M	SA193 B7	SA193 B7
Stud Nuts	SA194 2H	SA194 8M	SA194 2H	SA194 2H
Top Bellows Gasket	Fiber and Nitrile	Fiber and Nitrile	Fiber and Nitrile	Fiber and Nitrile
Guide	A351 CF8M SS	A351 CF8M SS	A494 M-35-2	A494 M-35-2
Bottom Bellows Gasket	Fiber and Nitrile	Fiber and Nitrile	Fiber and Nitrile	Fiber and Nitrile
Holder Insert (see note 6)	A582 416 SS	A582 416 SS	A582 416 SS	A582 416 SS
Ring Pin Gasket	Soft Iron	316 SS	Monel®	Monel®
Ring Pin	A479 316 SS	A479 316 SS	A479 316 SS	A479 316 SS
Disc Holder	A351 CF8M SS	A351 CF8M SS	A351 CF8M SS	A351 CF8M SS
Disc Retaining Ring	A313 302 SS	A313 302 SS	A313 302 SS	A313 302 SS
Disc	SA479 316 SS	SA479 316 SS	SA479 316 SS	SA479 316 SS
Adjusting Ring	A351 CF8M SS	A351 CF8M SS	A351 CF8M SS	A351 CF8M SS
Nozzle	SA351 CF8M SS	SA351 CF8M SS	SA351 CF8M SS	SA351 CF8M SS
Spring	(see note 4)	(see note 5)	Inconel® X-750	Inconel® X-750
Cap	A216 WCC	A351 CF8M SS	A216 WCC	A216 WCC
Bonnet	SA216 WCC	SA351 CF8M SS	SA216 WCC	SA217 WC6
Body	SA216 WCC	SA351 CF8M SS	SA217 WC6	SA217 WC6
Body Plug	Carbon Steel	A479 316 SS	316 SS	316 SS
Bellows	Inconel® 625 LCF	Inconel® 625 LCF	Inconel® 625 LCF	Inconel® 625 LCF
Bellows Flange	A240 316 SS	A240 316 SS	A240 316 SS	A240 316 SS
Bellows Nut	A479 316 SS	A479 316 SS	A479 316 SS	A479 316 SS
Bellows Spacer (see note 3)	A479 316 SS	A479 316 SS	A479 316 SS	A479 316 SS
Body Guide Gasket	Soft Iron	316 SS	Monel®	Monel®
Guide Bonnet Gasket	Soft Iron	316 SS	Monel®	Monel®
Lift Restrictor (see note 3)	A479 316 SS	A479 316 SS	A479 316 SS	A479 316 SS

Notes

1. Not applicable to Orifice D & E for RB/RBO.
2. Not applicable to RB/RBO Series.
3. Applicable only to Orifice D & E for RB/RBO.
4. Material for R/RO Series is Inconel® X-750. Material for RB/RBO Series is chrome vanadium.
5. Material for R/RO Series is Inconel® X-750. Material for RB/RBO Series is A313 316 SS.
6. Design Revision A only.

Options

Lifting Levers and Cap Options

Standard construction of pressure relief valves include a screwed cap. However, a wide variety of cap styles are available, at extra charge, to meet the most rigid requirements. A lifting mechanism is recommended to test for correct valve operation at all times where corrosion, caking, or any deposit could prevent the opening operation of the pressure relief valve. Foreign particles will often lodge under the seats of the valve when it discharges. The ability to lift the valve immediately and flush the obstruction may prevent damage and eliminate the possible shutdown of the unit. Pressure relief valves for Section VIII require a lift lever on all air, steam, and hot water valves (over 140°F, 60°C).

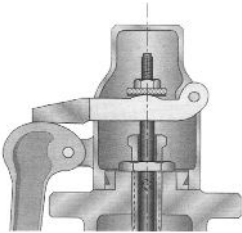

Open Lift Lever

This design type is suitable where periodic testing of the valve in location is desired to assure its operation. When the valve discharges, the fluid media will escape to atmosphere around the open lift lever assembly. This cap is not recommended where back pressure is present, or the escape of vapors to atmosphere is undesirable.

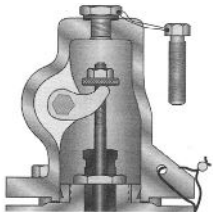

Packed Lift Lever

This design type should be selected where leakage of the media to the atmosphere during valve discharge or when subject to a back pressure would present a hazardous condition. This packed lever design is a completely sealed assembly to prevent any leakage.

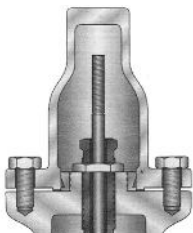

Bolted Cap

Preferred by those who consider the bolted and gasketed design superior to the standard screwed cap for applications with back pressure and/or vibration.

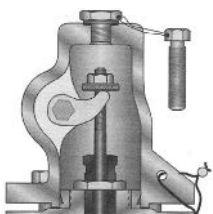

Gag Screw Test Gag

A Test Gag forces the valve into the closed position. This can be necessary for start-up configurations.

Caution: Test Gags must be removed prior to placing the pressure relief valve into service.

Options

Lift Lever Materials – R, RO, RB, RBO, and RS Series

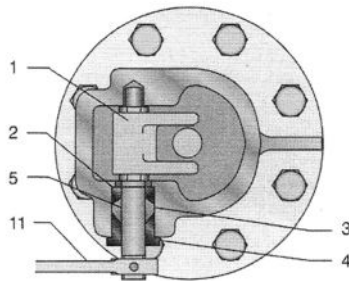
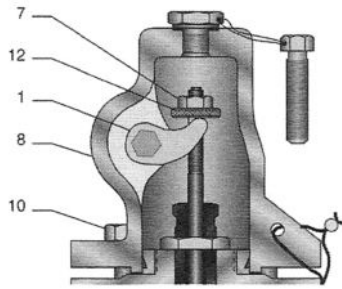

Packed Lift Lever Specifications

Component	S1, S2, S5, M1, M5, H1, H5, D1, D5, A1, A5, L1, SG, W1 and W2 Trims	S3, S4, L2, L3, and SS Trims	LC Trim
1. Yoke	A216 WCC	A351 CF8M	A351 CF8M
2. Collar	A479 316 SS	A479 316 SS	A479 316 SS
3. Packing	Graphite	Graphite	Graphite
4. Packing Gland	A479 316 SS	A479 316 SS	A479 316 SS
5. Shaft	A479 316 SS	A479 316 SS	A479 316 SS
6. Cotter Pin	Carbon Steel	Carbon Steel	Carbon Steel
7. Jam Nut	A582 303 SS	A582 303 SS	A582 303 SS
8. Cap	A216 WCC	A351 CF8M	A352 LCC
9. Cap Gasket	Soft Iron	Monel®	Monel®
10. Cap Bolt	A193 B7 CS	A193 B8	A193 B8
11. Lever	Carbon Steel	Carbon Steel	Carbon Steel
12. Lifting Disc	A479 316 SS	A479 316 SS	A479 316 SS

Options

Lift Lever Materials – R, RO, RB, RBO, and RS Series

Packed Lift Lever Specifications

Component	M2 Trim	M3 and M4 Trims	H2 Trim	H3 and H4 Trims
1. Yoke	Monel® A494	Monel® A494	Hastelloy® C A494	Hastelloy® C A494
2. Collar	Monel® B164	Monel® B164	Hastelloy® C B574	Hastelloy® C B574
3. Packing	Graphite	Graphite	Graphite	Graphite
4. Packing Gland	A479 316 SS	Monel® B164	A479 316 SS	Hastelloy® C B574
5. Shaft	Monel® B164	Monel® B164	Hastelloy® C B574	Hastelloy® C B574
6. Cotter Pin	Carbon Steel	Carbon Steel	Carbon Steel	Carbon Steel
7. Jam Nut	Monel® B164	Monel® B164	Hastelloy® C B574	Hastelloy® C B574
8. Cap	A216 WCC	Monel® A494	A216 WCC	Hastelloy® C A494
9. Cap Gasket	Monel®	Monel®	Monel®	Monel®
10. Cap Bolt	A193 B7 CS	Monel® F468	A193 B7 CS	Hastelloy® C F468
11. Lever	Carbon Steel	Carbon Steel	Carbon Steel	Carbon Steel
12. Lifting Disc	Monel® B164	Monel® B164	Hastelloy® C B574	Hastelloy® C B574

Component	D2 Trim	D3 and D4 Trims	A2 Trim	A3 and A4 Trims
1. Yoke	A995 CD3MN	A995 CD3MN	A351 CN7M	A351 CN7M
2. Collar	A479 UNS S32205	A479 UNS S32205	B473 UNS N08020	B473 UNS N08020
3. Packing	Graphite	Graphite	Graphite	Graphite
4. Packing Gland	A479 316 SS	A479 UNS S32205	A479 316 SS	B473 UNS N08020
5. Shaft	A479 UNS S32205	A479 UNS S32205	B473 UNS N08020	B473 UNS N08020
6. Cotter Pin	Carbon Steel	Carbon Steel	Carbon Steel	Carbon Steel
7. Jam Nut	A479 UNS S32205	A479 UNS S32205	B473 UNS N08020	B473 UNS N08020
8. Cap	A216 WCC	A995 CD3MN	A216 WCC	A351 CN7M
9. Cap Gasket	Monel®	Monel®	Monel®	Monel®
10. Cap Bolt	SA193 B7	A193 B8	SA193 B7	Alloy 20
11. Lever	Carbon Steel	Carbon Steel	Carbon Steel	Carbon Steel
12. Lifting Disc	A479 UNS S32205	A479 UNS S32205	B473 UNS N08020	B473 UNS N08020

Options

Lift Lever Materials – R, RO, RB, RBO, and RS Series

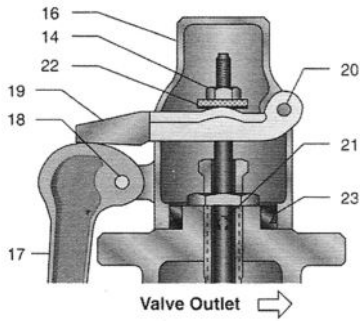

Open Lift Lever Specifications

Component	All Trims
14. Jam Nut	A582 303 SS
15. Cotter Pin	Carbon Steel
16. Cap	Carbon Steel
17. Lever	Carbon Steel
18. Lever Pin	A108 CS
19. Yoke	Carbon Steel
20. Yoke Pin	A108 CS
21. Set Screw	A108 CS
22. Lifting Disc	A479 316 SS
23. Adapter	A108 CS

O-ring Seat Seals – RO/RBO Series

O-ring seat seals are effective seat-leak stoppers, even in the severest application, saving valuable product and maintenance costs. The O-ring seat seal assures maximum tightness at pressures closer to the critical set pressure than is possible in a standard metal-to-metal seat valve.

ARI-Reyco's unique O-ring seat seal design features spring loading on the disc seat, not on either the O-ring itself or on the O-ring retaining plate. This feature limits seal distortion—chiefly under heavy spring load or reclosure impact—that occurs in a valve using the O-ring retainer as a seat. This unique design locates the O-ring seal on the inside of the seat diameter, thus barring the fluid media from the metal-to-metal seat surfaces and minimizing corrosion. The design permits O-ring seat seals to be used up to the maximum pressure limit of each valve series. In the event of O-ring damage, the optically smooth, lapped seats provide the required commercial tightness standard of metal-to-metal seats until replacement is possible.

An O-ring seat seal can solve the following problems:

1. Leakage caused by corrosion

Corrosive fluids may erode sealing surfaces and cause damaging leakage. O-ring seat seal safety relief valves resist such corrosive action through the proper use of O-ring materials to seal against leakage, as well as shield and protect the valve's optically flat, metal-to-metal surfaces.

2. Simmer from pressure buildup

Almost all pressure relief valves go through a characteristic “simmering stage” before sufficient pressure in the huddling chamber “pops” it open. During momentary surges and pressure buildups, the valve frequently simmers without popping. During this period, the valve disc is floating. When pressure recedes, the seating surfaces often become misaligned, causing leakage. The O-ring seat seal overcomes this problem and permits tight closure after the pressure drops below simmer. Should the valve pop, the valve recloses completely and tightly, pop after pop, without damaging the O-ring.

3. High operating pressures

In process applications, operating pressures are often close to valve set pressures. As the system pressure nears valve set pressure, the net spring force affecting seat tightness is greatly reduced. ARI-Reyco's O-ring seat seal design permits higher operating pressures while maintaining absolute tightness.

4. Leakage from light fluids

Fluids such as hydrogen, helium, light hydrocarbons and anhydrous ammonia are light and difficult to contain. They easily infiltrate the metal-to-metal type seat, resulting in costly leaks. This O-ring seat seal eliminates such leakage.

5. Metal-to-metal seat damage

Occasionally, minute particles of foreign matter are carried in the flow medium, damaging the metal-to-metal seat during valve closure. The O-ring seat seal absorbs the full impact of such particles and minimizes seat damage and deformation of mating metal surfaces.

O-ring Selector Chart – RO/RBO Series

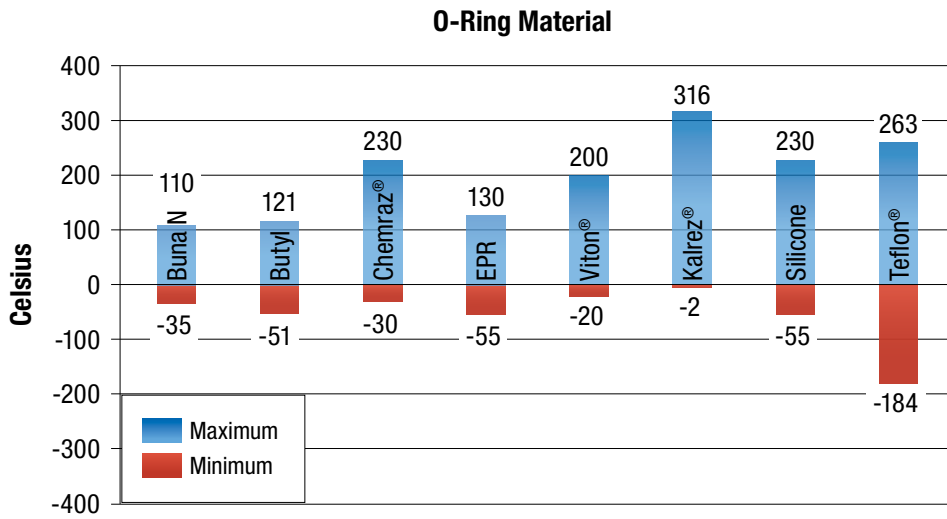
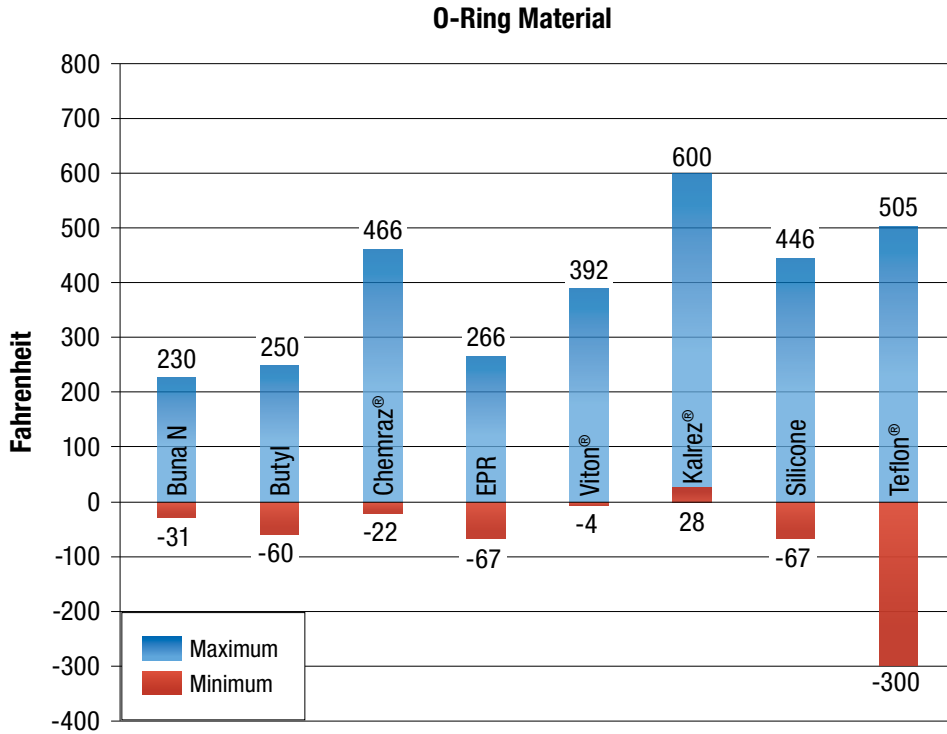

Notes

1. Viton® is a registered trademark of DuPont Performance Elastomers.
2. Teflon® is the trademark of DuPont Company. Teflon® is the family name for DuPont's range of fluoropolymers such as FEP, PFA, and Tefzel.
3. Kalrez® is a registered trademark of DuPont Performance Elastomers.
4. Customer is responsible for material compatibility to service media, temperature, and pressure.

Procedures for Sizing Safety Relief Valves

In all problems of sizing safety relief valves, the relieving pressure and the required rate of flow (relieving capacity) under specified conditions must be known. Then, refer to the capacity tables, or use the proper formula, to solve for the required effective orifice area.

Contact your local representative for more information. If all the necessary information is provided, ARI-Reyco will gladly perform the calculations and provide a detailed sizing sheet for each valve.

Sizing by Formula

It is frequently more convenient to assemble all the data relating to a given safety relief valve sizing problem and determine the required orifice or discharge area by formula. It is then quite simple to match the required area against the listed areas available in the type of valve selected.

Solving by formula requires you first establish the relieving pressure, constant back pressure, temperature of the medium, specific gravity, and the volume to be handled.

Sizing from Capacity Tables

Air/Gas

ARI-Reyco air capacity tables are based on free air under standard conditions (atmospheric pressure and 68°F).

Steam

The standard steam capacity tables are expressed in terms of pounds of saturated steam per hour, at set pressure, plus 10% overpressure. Valve capacity, as defined by Section VIII of the ASME Boiler and Pressure Vessel Code (BPVC), is expressed as 90% of the total capacity rating.

For superheated steam, capacities must be corrected by the applicable superheat correction factor.

Liquids

The capacities of R Series Valves for liquid services are expressed in terms of water, in gallons per minute at set gauge pressure plus 10% accumulation or over pressure.

For liquids other than water, capacities may be determined from the water capacity tables by correcting for specific gravity.

Caution must be exercised where liquids of high viscosity are being handled. The calculations necessary to determine relief valve capacity for such fluids are complex, and beyond the scope of this outline. However all such problems may be referred to ARI-Reyco with information on viscosity, relieving pressure, permissible accumulation, temperature of the medium, specific gravity, and the volume to be handled.

Technical Information

Sizing and Selection by Formula

Air/Gas Equations

The formula for the discharge area of a gas valve depends on the type of flowrate:

Volumetric Flow:

$$A = \frac{V \sqrt{M \times T \times Z}}{6.32 \times C \times K \times P_1 \times K_b}$$

Mass Flow:

$$A = \frac{W}{C \times K \times P_1 \times K_b} \sqrt{\frac{T \times Z}{M}}$$

The gas or vapor constant, C , coefficient for air or gas can be calculated by:

In USC units:

$$C = 0.03948 \sqrt{k \left(\frac{2}{k+1} \right)^{\frac{k+1}{k-1}}}$$

In SI units:

$$C = 520 \sqrt{k \left(\frac{2}{k+1} \right)^{\frac{k+1}{k-1}}}$$

Air/Gas Symbol Legend

Symbol	Description	USC Units	SI Units
A	Required effective discharge area of the valve	in ²	cm ²
C	Gas constant based on k (if unknown, use $C = 315$)		
k	Ratio of specific heats for an ideal gas		
M	Molecular weight of gas or vapor		
P_1	Relieving pressure = set pressure + allowable overpressure + atmospheric pressure	psia	bara
T	Relieving temperature (°K = °C + 273 or °R = °F + 460)	°R	°K
V	Flow rate: in SCFM at 14.7 psia and 60°F or Nm ³ /hr at 1.03 bara and 0°C	SCFM	Nm ³ /hr
W	Flow rate	lbs/hr	kg/hr
Z	Compressibility factor		
K	Coefficient of discharge (for the R Series, use $K = 0.860$)		
K_b	Back pressure correction factor		

Technical Information

Sizing and Selection by Formula

Steam Symbol Legend

Symbol	Description	USC Units	SI Units
A	Required effective discharge area of the valve	in ²	cm ²
P_1	Relieving pressure = set pressure + allowable overpressure + atmospheric pressure	psia	bara
W	Flow rate	lbs/hr	kg/hr
K	Coefficient of discharge (for the R Series, use $K = 0.860$)		
K_n	Napier correction factor for steam flowing pressures in excess of 1500 psig [105 barg]		
K_{sh}	Superheat steam correction factor		

Liquid Symbol Legend

Symbol	Description	USC Units	SI Units
A	Required effective discharge area of the valve	in ²	cm ²
G	Specific gravity of the liquid referred to water = 1.00 at 70°F or 20°C		
P_1	Relieving pressure for liquids = set pressure + allowable overpressure	psia	bara
P_2	Back pressure	psig	barg
Q	Flow rate (liquids)	gpm	M ³ /hr
K	Coefficient of discharge (for the R Series, use $K = 0.724$)		
K_v	Viscosity correction factor		
K_w	Back pressure correction factor for liquids and balanced bellows valves		

Steam Equations

The required discharge area, A , for a steam valve is given by:

$$A = \frac{W}{51.5 \times P_1 \times K \times K_n \times K_{sh}}$$

Liquid Equations

The required discharge area, A , for a liquid valve is given by:

$$A = \frac{Q \sqrt{G}}{38 \times K \times K_w \times K_v \sqrt{P_1 - P_2}}$$

Technical Information

Superheated Steam Sizing Correction Table

Temperature Corrections for Superheated Steam

Set Pressure (psig)	Sat. Steam Temp (°F)	Steam Temperature (°F)																															
		280	300	320	340	360	380	400	420	440	460	480	500	520	540	560	580	600	620														
15	250	1.00	1.00	1.00	.99	.99	.98	.98	.97	.96	.95	.94	.93	.92	.91	.90	.89	.88	.87														
20	259	1.00	1.00	1.00	.99	.99	.98	.98	.97	.96	.95	.94	.93	.92	.91	.90	.89	.88	.87														
40	287		1.00	1.00	1.00	.99	.99	.98	.97	.96	.95	.94	.93	.92	.91	.90	.89	.88	.87														
60	308			1.00	1.00	.99	.99	.98	.97	.96	.95	.94	.93	.92	.91	.90	.89	.88	.87														
80	324				1.00	1.00	.99	.99	.98	.97	.96	.94	.93	.92	.91	.90	.89	.89	.88														
100	338					1.00	1.00	.99	.98	.97	.96	.95	.94	.93	.92	.91	.90	.89	.88														
120	350						1.00	1.00	.99	.98	.97	.96	.95	.94	.93	.92	.91	.90	.89	.88													
140	361							1.00	1.00	.99	.98	.96	.95	.94	.93	.92	.91	.90	.89	.88													
160	371								1.00	.99	.98	.97	.95	.94	.93	.92	.91	.90	.89	.88													
180	380									1.00	.99	.98	.97	.96	.95	.93	.92	.91	.90	.89	.88												
200	388										1.00	.99	.99	.97	.96	.95	.93	.92	.91	.90	.89	.88											
220	395											1.00	1.00	.99	.98	.96	.95	.94	.93	.92	.91	.90	.89										
240	403												1.00	.99	.98	.97	.95	.94	.93	.92	.91	.90	.89										
260	409													1.00	.99	.98	.97	.96	.94	.93	.92	.91	.90	.89									
280	416														1.00	1.00	.99	.97	.96	.95	.93	.92	.91	.90	.89								
300	422															1.00	.99	.98	.96	.95	.93	.92	.91	.90	.89								
350	436																1.00	1.00	.99	.97	.96	.94	.93	.92	.91	.90							
400	448																	1.00	.99	.98	.96	.95	.93	.92	.91	.90							
450	460																		1.00	.99	.97	.96	.94	.93	.92	.91							
500	470																			1.00	.99	.98	.96	.94	.93	.92	.91						
550	480																				1.00	.99	.97	.95	.94	.92	.91						
600	489																					1.00	.99	.98	.96	.94	.93	.92					
650	497																						1.00	.99	.97	.95	.94	.92					
700	506																							1.00	.99	.97	.96	.94	.93				
750	513																								1.00	1.00	.98	.96	.95	.93			
800	520																									1.00	.99	.97	.95	.94			
850	527																										1.00	.99	.98	.96	.94		
900	533																											1.00	1.00	.99	.97	.95	
950	540																												1.00	.99	.97	.95	
1000	546																													1.00	.99	.98	.96

Notes

For Capacities of Superheated Steam, multiply the Saturated Steam Capacity by it's Correction Factor.

Technical Information

Superheated Steam Sizing Correction Table

Temperature Corrections for Superheated Steam

Set Pressure (psig)	Sat. Steam Temp (°F)	Steam Temperature (°F)																	
		640	660	680	700	720	740	760	780	800	820	840	860	880	900	920	940	960	980
15	250	.86	.86	.85	.84	.83	.83	.82	.81	.81	.80	.79	.79	.78	.78	.77	.76	.76	.75
20	259	.86	.86	.85	.84	.83	.83	.82	.81	.81	.80	.79	.79	.78	.78	.77	.77	.76	.75
40	287	.87	.86	.85	.84	.84	.83	.82	.82	.81	.80	.79	.79	.78	.78	.77	.77	.76	.75
60	308	.87	.86	.85	.84	.84	.83	.82	.82	.81	.80	.80	.79	.78	.78	.77	.77	.76	.76
80	324	.87	.86	.85	.84	.84	.83	.82	.82	.81	.80	.80	.79	.78	.78	.77	.77	.76	.76
100	338	.87	.86	.85	.85	.84	.83	.82	.82	.81	.80	.80	.79	.78	.78	.77	.77	.76	.76
120	350	.87	.86	.85	.85	.84	.83	.82	.82	.81	.80	.80	.79	.78	.78	.77	.77	.76	.76
140	361	.87	.86	.85	.85	.84	.83	.82	.82	.81	.80	.80	.79	.78	.78	.77	.77	.76	.76
160	371	.87	.86	.86	.85	.84	.83	.82	.82	.81	.80	.80	.79	.79	.78	.77	.77	.76	.76
180	380	.87	.86	.86	.85	.84	.83	.82	.82	.81	.80	.80	.79	.79	.78	.77	.77	.76	.76
200	388	.87	.86	.86	.85	.84	.83	.83	.82	.81	.81	.80	.79	.79	.78	.77	.77	.76	.76
220	395	.88	.87	.86	.85	.84	.84	.83	.82	.81	.81	.80	.79	.79	.78	.78	.77	.76	.76
240	403	.88	.87	.86	.85	.84	.84	.83	.82	.81	.81	.80	.79	.79	.78	.78	.77	.76	.76
260	409	.88	.87	.86	.85	.85	.84	.83	.82	.81	.81	.80	.79	.79	.78	.78	.77	.76	.76
280	416	.88	.87	.86	.85	.85	.84	.83	.82	.82	.81	.80	.80	.79	.78	.78	.77	.77	.76
300	422	.88	.87	.86	.86	.85	.84	.83	.82	.82	.81	.80	.80	.79	.78	.78	.77	.77	.76
350	436	.89	.88	.87	.86	.85	.84	.83	.83	.82	.81	.81	.80	.79	.78	.78	.77	.77	.76
400	448	.89	.88	.87	.86	.85	.84	.84	.83	.82	.81	.81	.80	.79	.79	.78	.77	.77	.76
450	460	.89	.88	.87	.86	.86	.85	.84	.83	.82	.82	.81	.80	.79	.79	.78	.78	.77	.76
500	470	.90	.89	.88	.87	.86	.85	.84	.83	.82	.82	.81	.80	.79	.79	.78	.78	.77	.76
550	480	.90	.89	.88	.87	.86	.85	.84	.83	.82	.82	.81	.80	.80	.79	.78	.78	.77	.76
600	489	.90	.89	.88	.87	.86	.85	.84	.84	.83	.82	.81	.80	.80	.79	.78	.78	.77	.76
650	497	.91	.90	.89	.87	.86	.86	.85	.84	.83	.82	.81	.81	.80	.79	.78	.78	.77	.77
700	506	.91	.90	.89	.88	.87	.86	.85	.84	.83	.82	.81	.81	.80	.79	.79	.78	.77	.77
750	513	.92	.90	.89	.88	.87	.86	.85	.84	.83	.83	.82	.81	.80	.79	.79	.78	.77	.77
800	520	.92	.91	.90	.88	.87	.86	.85	.84	.84	.83	.82	.81	.80	.80	.79	.78	.78	.77
850	527	.93	.92	.90	.89	.88	.87	.86	.85	.84	.83	.82	.81	.81	.80	.79	.78	.78	.77
900	533	.93	.92	.90	.89	.88	.87	.86	.85	.84	.83	.82	.81	.81	.80	.79	.79	.78	.77
950	540	.94	.92	.91	.89	.88	.87	.86	.85	.84	.83	.82	.82	.81	.80	.79	.79	.78	.77
1000	546	.94	.93	.91	.90	.89	.87	.86	.85	.84	.83	.83	.82	.81	.80	.79	.79	.78	.77

Notes

For Capacities of Superheated Steam, multiply the Saturated Steam Capacity by it's Correction Factor.

Technical Information

Air/Gas Capacities: Orifices D thru K

Capacity ratings based on standard cubic feet per minute (SCFM) of Air at 10% over pressure. NB certified at 90% of average capacities, in accordance with the latest ASME Code Requirements.

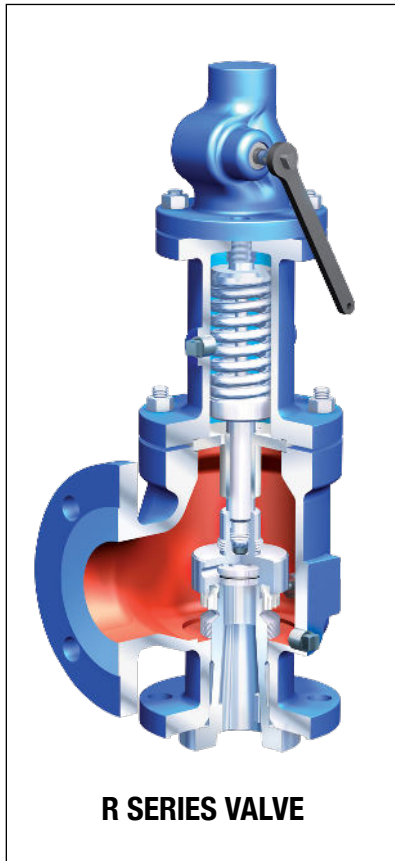

R SERIES VALVE

Note

Valves set under 15 psig are not ASME or NB code stamped.

R, RO, RB, RBO, and RS Series: Air/Gas Capacities ASME Section VIII

Set Pressure (psig)	Capacities (SCFM)						
	Orifice D	Orifice E	Orifice F	Orifice G	Orifice H	Orifice J	Orifice K
Actual Orifice Sizing:	0.122 in ²	0.217 in ²	0.340 in ²	0.558 in ²	0.869 in ²	1.427 in ²	2.036 in ²
5	44	78	122	200	311	511	729
10	53	95	148	244	379	623	889
20	72	129	202	332	516	848	1210
30	92	163	256	420	653	1073	1531
40	113	201	315	516	804	1321	1884
50	134	239	374	613	955	1568	2237
60	155	276	433	710	1106	1815	2590
70	176	314	492	807	1256	2063	2943
80	197	352	550	903	1407	2310	3296
90	218	389	609	1000	1558	2558	3649
100	240	427	668	1097	1708	2805	4002
120	282	503	786	1290	2010	3300	4709
140	324	578	904	1484	2311	3795	5415
160	366	653	1022	1678	2612	4290	6121
180	409	729	1140	1871	2914	4785	6827
200	451	804	1258	2065	3215	5280	7533
220	493	879	1376	2258	3517	5775	8239
240	536	955	1494	2452	3818	6270	8945
260	578	1030	1612	2645	4119	6765	9652
280	620	1105	1730	2839	4421	7260	10358
300	662	1181	1848	3032	4722	7754	11064
320	705	1256	1966	3226	5024	8249	11770
340	747	1332	2083	3419	5325	8744	12476
360	789	1407	2201	3613	5626	9239	13182
380	832	1482	2319	3806	5928	9734	13888
400	874	1558	2437	4000	6229	10229	14594
420	916	1633	2555	4193	6531	10724	15301
440	958	1708	2673	4387	6832	11219	16007
460	1001	1784	2791	4580	7133	11714	16713
480	1043	1859	2909	4774	7435	12209	17419
500	1085	1934	3027	4967	7736	12704	18125
600	1297	2311	3616	5935	9243	15178	21656
700	1508	2688	4206	6903	10750	17653	25186
800	1719	3065	4796	7870	12257	20127	28717
900	1931	3442	5385	8838	13764	22602	32248
1000	2142	3819	5975	9806	15271	25076	35778
2000	4256	7587	11871	19482	30340	49822	71085
3000	6370	11355	17767	29158			
4000	8484	15123	23663				
5000	10598	18891	29559				
6000	12712	22660					

Technical Information

Air/Gas Capacities: Orifices L thru T

R, RO, RB, RBO, and RS Series: Air/Gas Capacities ASME Section VIII

Set Pressure (psig)	Capacities (SCFM)						
	Orifice L	Orifice M	Orifice N	Orifice P	Orifice Q	Orifice R	Orifice T
Actual Orifice Sizing:	3.160 in ²	3.987 in ²	4.807 in ²	7.07 in ²	12.24 in ²	17.72 in ²	29.75 in ²
5	1131	1427	1720	2530	4380	6341	10646
10	1380	1741	2099	3087	5345	7738	12991
20	1878	2370	2857	4202	7275	10531	17681
30	2376	2998	3615	5316	9204	13325	22371
40	2924	3690	4448	6542	11327	16398	27530
50	3472	4381	5282	7768	13449	19471	32689
60	4020	5072	6116	8995	15572	22544	37848
70	4568	5764	6949	10221	17694	25616	43007
80	5116	6455	7783	11447	19817	28689	48166
90	5664	7146	8616	12673	21939	31762	53325
100	6212	7838	9450	13899	24062	34835	58484
120	7308	9221	11117	16351	28307	40981	68802
140	8404	10603	12784	18803	32552	47126	79120
160	9500	11986	14451	21255	36797	53272	89438
180	10596	13369	16119	23707	41042	59418	99756
200	11692	14752	17786	26159	45288	65563	110074
220	12788	16135	19453	28611	49533	71709	120392
240	13884	17517	21120	31063	53778	77855	130710
260	14980	18900	22787	33515	58023	84000	141028
280	16076	20283	24454	35967	62268	90146	151346
300	17172	21666	26122	38419	66513	96292	161664
320	18268	23048	27789	40871	70758		
340	19364	24431	29456	43323	75003		
360	20460	25814	31123	45775	79248		
380	21556	27197	32790	48227	83494		
400	22651	28580	34457	50679	87739		
420	23747	29962	36125	53131	91984		
440	24843	31345	37792	55583	96229		
460	25939	32728	39459	58035	100474		
480	27035	34111	41126	60487	104719		
500	28131	35493	42793	62939	108964		
600	33611	42407	51129	75199	130190		
700	39091	49321	59465	87460			
800	44571	56235	67801	99720			
900	50050	63149	76137	111980			
1000	55530	70063	84473	124240			
2000							
3000							
4000							
5000							
6000							

Capacity ratings based on standard cubic feet per minute (SCFM) of Air at 10% over pressure. NB certified at 90% of average capacities, in accordance with the latest ASME Code Requirements.

CALCULATING CAPACITIES:

For Air, at 60°F and 14.7 psia:

$$W = 18.331 \times A \times K \times P$$

For Gas or Vapor:

$$W = C \times A \times K \times P \times \sqrt{\frac{M}{T}}$$

W = rated capacity, in SCFM

A = nozzle throat area, in inches²
(use Actual Orifice Sizing)

C = ratio of specific heats, C_p/C_v

K = certified coefficient
(ARI-Reyco Air/Gas = 0.860)

M = molecular weight

P = 14.7 + stamped set pressure +
(10% of set pressure OR 3 psi)
(choose whichever is greater)

T = absolute temperature at inlet, in °R
(°R = °F + 460)

Note

Valves set under 15 psig are not ASME or NB code stamped.

Technical Information

Steam Capacities: Orifices D thru K

Capacity ratings based on pounds per hour (lb/hr) of saturated steam at 10% over pressure. NB certified at 90% of average capacities, in accordance with the latest ASME Code Requirements.

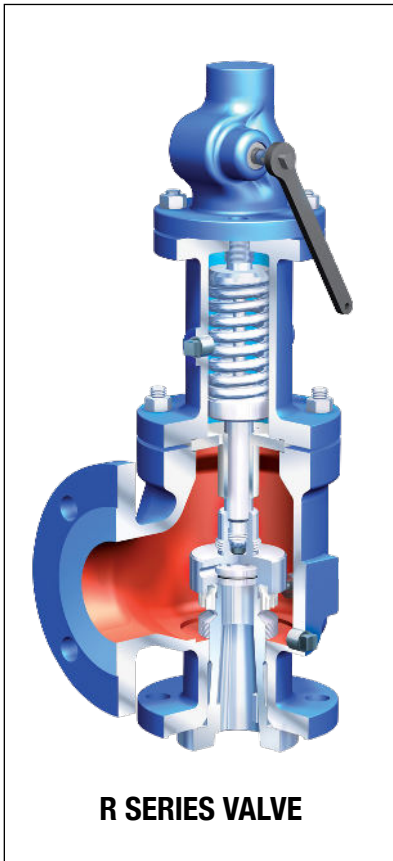

Note

Valves set under 15 psig are not ASME or NB code stamped.

R, RO, RB, RBO, and RS Series: Steam Capacities ASME Section VIII

Set Pressure (psig)	Capacities (lb/hr)						
	Orifice D	Orifice E	Orifice F	Orifice G	Orifice H	Orifice J	Orifice K
Actual Orifice Sizing:	0.122 in ²	0.217 in ²	0.340 in ²	0.558 in ²	0.869 in ²	1.427 in ²	2.036 in ²
5	123	218	342	561	874	1435	2047
10	150	267	417	685	1066	1751	2498
20	204	363	568	932	1451	2383	3400
30	258	459	718	1179	1836	3015	4301
40	317	565	884	1451	2259	3710	5293
50	376	671	1050	1723	2683	4405	6285
60	436	777	1215	1994	3106	5100	7277
70	495	883	1381	2266	3529	5796	8269
80	554	988	1547	2538	3953	6491	9261
90	614	1094	1712	2810	4376	7186	10253
100	673	1200	1878	3082	4799	7881	11245
120	792	1412	2209	3626	5646	9272	13229
140	911	1624	2540	4169	6493	10662	15212
160	1030	1835	2872	4713	7340	12053	17196
180	1148	2047	3203	5257	8186	13443	19180
200	1267	2259	3534	5800	9033	14833	21164
220	1386	2471	3866	6344	9880	16224	23148
240	1505	2682	4197	6888	10727	17614	25132
260	1623	2894	4528	7431	11573	19005	27115
280	1742	3106	4859	7975	12420	20395	29099
300	1861	3317	5191	8519	13267	21786	31083
320	1980	3529	5522	9063	14114	23176	33067
340	2099	3741	5853	9606	14960	24567	35051
360	2217	3953	6185	10150	15807	25957	37035
380	2336	4164	6516	10694	16654	27347	39018
400	2455	4376	6847	11237	17500	28738	41002
420	2574	4588	7178	11781	18347	30128	42986
440	2692	4800	7510	12325	19194	31519	44970
460	2811	5011	7841	12868	20041	32909	46954
480	2930	5223	8172	13412	20887	34300	48938
500	3049	5435	8504	13956	21734	35690	50922
600	3643	6493	10160	16674	25968	42642	60841
700	4237	7552	11816	19393	30202	49594	70760
800	4830	8611	13473	22111	34435	56547	80679
900	5424	9669	15129	24830	38669	63499	90598
1000	6018	10728	16786	27548	42903	70451	100517
2000	11957	21315	33350	54734	85239	139973	199709
3000	17896	31901	49915	81919			

Technical Information

Steam Capacities: Orifices L thru T

R, RO, RB, RBO, and RS Series: Steam Capacities ASME Section VIII

Set Pressure (psig)	Capacities (lb/hr)						
	Orifice L	Orifice M	Orifice N	Orifice P	Orifice Q	Orifice R	Orifice T
Actual Orifice Sizing:	3.160 in ²	3.987 in ²	4.807 in ²	7.07 in ²	12.24 in ²	17.72 in ²	29.75 in ²
5	3177	4008	4833	7108	12306	17815	29910
10	3877	4891	5897	8674	15016	21739	36498
20	5276	6657	8026	11805	20438	29588	49675
30	6676	8423	10155	14936	25859	37436	62851
40	8215	10365	12497	18381	31822	46069	77345
50	9755	12308	14839	21825	37785	54702	91839
60	11294	14250	17181	25270	43748	63335	106333
70	12834	16193	19523	28714	49711	71968	120826
80	14374	18135	21865	32158	55675	80601	135320
90	15913	20078	24207	35603	61638	89234	149814
100	17453	22020	26549	39047	67601	97867	164308
120	20532	25905	31233	45936	79527	115133	193296
140	23611	29790	35917	52825	91454	132399	222284
160	26690	33675	40600	59714	103380	149665	251272
180	29769	37559	45284	66603	115307	166931	280259
200	32848	41444	49968	73492	127233	184197	309247
220	35927	45329	54652	80381	139160	201463	338235
240	39006	49214	59336	87269	151086	218729	367223
260	42085	53099	64020	94158	163012	235995	396211
280	45164	56984	68703	101047	174939	253261	425198
300	48243	60869	73387	107936	186865	270527	454186
320	51322	64753	78071	114825	198792		
340	54401	68638	82755	121714	210718		
360	57480	72523	87439	128603	222644		
380	60559	76408	92123	135491	234571		
400	63638	80293	96807	142380	246497		
420	66717	84178	101490	149269	258424		
440	69796	88063	106174	156158	270350		
460	72875	91947	110858	163047	282276		
480	75954	95832	115542	169936	294203		
500	79033	99717	120226	176825	306129		
600	94429	119141	143645	211269	365761		
700	109824	138566	167064	245713			
800	125219	157990	190483	280158			
900	140614	177414	213903	314602			
1000	156009	196838	237322	349046			
2000							
3000							

Capacity ratings based on pounds per hour (lb/hr) of saturated steam at 10% over pressure. NB certified at 90% of average capacities, in accordance with the latest ASME Code Requirements.

CALCULATING CAPACITIES:

For Steam, at pressures under 1500 psi:

$$W = 51.5 \times A \times K \times P$$

For Steam, at pressures over 1500 psi and up to 3000 psi:

$$W = 51.5 \times A \times K \times P \times \left(\frac{0.1906P - 1000}{0.2292P - 1061} \right)$$

W = rated capacity, in lb/hr

A = nozzle throat area, in inches²
(use Actual Orifice Sizing)

K = certified coefficient
(ARI-Reyco Steam Service = 0.860)

P = 14.7 + stamped set pressure +
(10% of set pressure OR 3 psi)
(choose whichever is greater)

Note

Valves set under 15 psig are not ASME or NB code stamped.

Technical Information

Liquid Capacities: Orifices D thru K

Capacity ratings based on gallons per minute (GPM) at 10% over pressure. NB certified at 90% of average capacities, in accordance with the latest ASME Code Requirements.

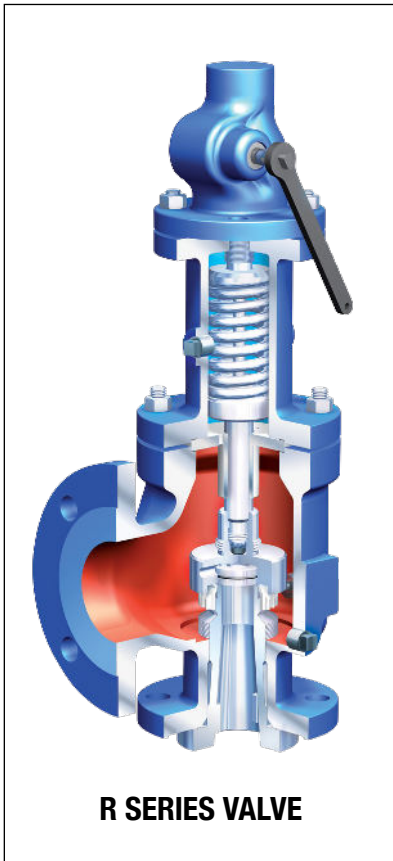

R SERIES VALVE

Note

Valves set under 15 psig are not ASME or NB code stamped.

R, RO, RB, RBO, and RS Series: Liquid Capacities ASME Section VIII

Set Pressure (psig)	Capacities (GPM)						
	Orifice D	Orifice E	Orifice F	Orifice G	Orifice H	Orifice J	Orifice K
Actual Orifice Sizing:	0.122 in ²	0.217 in ²	0.340 in ²	0.558 in ²	0.869 in ²	1.427 in ²	2.036 in ²
5	9	17	26	43	68	111	158
10	12	22	34	55	86	142	202
20	16	29	45	74	115	188	269
30	19	34	54	88	137	226	322
40	22	40	62	102	159	260	372
50	25	44	69	114	177	291	415
60	27	49	76	125	194	319	455
70	29	52	82	135	210	344	492
80	31	56	88	144	224	368	525
90	33	59	93	153	238	391	557
100	35	63	98	161	251	412	587
120	39	69	107	176	275	451	644
140	42	74	116	191	297	487	695
160	44	79	124	204	317	521	743
180	47	84	132	216	336	552	788
200	50	89	139	228	355	582	831
220	52	93	146	239	372	611	871
240	54	97	152	249	388	638	910
260	57	101	158	260	404	664	947
280	59	105	164	269	420	689	983
300	61	109	170	279	434	713	1018
320	63	112	175	288	449	737	1051
340	65	116	181	297	462	759	1083
360	67	119	186	305	476	781	1115
380	69	122	191	314	489	803	1145
400	70	125	196	322	501	823	1175
420	72	128	201	330	514	844	1204
440	74	132	206	338	526	864	1232
460	75	134	210	345	538	883	1260
480	77	137	215	353	549	902	1287
500	79	140	219	360	561	921	1314
600	86	154	240	394	614	1009	1439
700	93	166	260	426	663	1089	1554
800	99	177	277	455	709	1165	1662
900	106	188	294	483	752	1235	1762
1000	111	198	310	509	793	1302	1858
2000	157	280	439	720	1121	1841	2627
3000	193	343	537	882			
4000	222	397	620				
5000	249	443	694				
6000	272	486					

Technical Information

Liquid Capacities: Orifices L thru T

R, RO, RB, RBO, and RS Series: Liquid Capacities ASME Section VIII

Set Pressure (psig)	Capacities (GPM)						
	Orifice L	Orifice M	Orifice N	Orifice P	Orifice Q	Orifice R	Orifice T
Actual Orifice Sizing:	3.160 in ²	3.987 in ²	4.807 in ²	7.07 in ²	12.24 in ²	17.72 in ²	29.75 in ²
5	246	310	374	550	952	1379	2315
10	313	395	477	701	1214	1758	2951
20	417	526	634	933	1615	2338	3925
30	499	630	760	1117	1934	2800	4702
40	577	728	877	1290	2234	3234	5429
50	645	813	981	1442	2497	3615	6070
60	706	891	1074	1580	2736	3960	6649
70	763	962	1160	1707	2955	4278	7182
80	816	1029	1241	1825	3159	4573	7678
90	865	1091	1316	1935	3350	4851	8144
100	912	1150	1387	2040	3532	5113	8584
120	999	1260	1519	2235	3869	5601	9403
140	1079	1361	1641	2414	4179	6050	10157
160	1153	1455	1754	2580	4467	6467	10858
180	1223	1543	1861	2737	4738	6860	11517
200	1289	1627	1962	2885	4995	7231	12140
220	1352	1706	2057	3026	5238	7584	12732
240	1413	1782	2149	3160	5471	7921	13298
260	1470	1855	2236	3289	5695	8244	13841
280	1526	1925	2321	3414	5910	8556	14364
300	1579	1993	2402	3533	6117	8856	14868
320	1631	2058	2481	3649	6318		
340	1681	2121	2558	3762	6512		
360	1730	2183	2632	3871	6701		
380	1777	2243	2704	3977	6885		
400	1824	2301	2774	4080	7063		
420	1869	2358	2843	4181	7238		
440	1913	2413	2909	4279	7408		
460	1956	2467	2975	4375	7575		
480	1998	2520	3039	4469	7738		
500	2039	2572	3101	4562	7897		
600	2233	2818	3397	4997	8651		
700	2412	3044	3670	5397			
800	2579	3254	3923	5770			
900	2735	3451	4161	6120			
1000	2883	3638	4386	6451			
2000							
3000							
4000							
5000							
6000							

Capacity ratings based on gallons per minute (GPM) at 10% over pressure. NB certified at 90% of average capacities, in accordance with the latest ASME Code Requirements.

CALCULATING CAPACITIES:

For Liquid:

$$W = 4.814 \times A \times K \times \sqrt{w(P - P_d)}$$

For Water, at 70°F:

$$W = 37.999 \times A \times K \times \sqrt{P - P_d}$$

W = rated capacity, in GPM

A = nozzle throat area, in inches²
(use Actual Orifice Sizing)

K = certified coefficient
(ARI-Reyco Liquid Service = 0.724)

P = 14.7 + stamped set pressure +
(10% of set pressure OR 3 psi)
(choose whichever is greater)

P_d = pressure at discharge from valve,
in psia

w = specific weight

Note

Valves set under 15 psig are not ASME or NB code stamped.

ARI product diversity

Control

Control valves
STEVl®



Pressure reducing valve
PREDU®

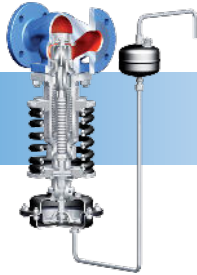

Excess pressure valve
PREDEX®

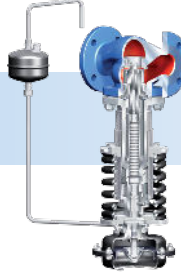

Temperature controller without
auxiliary power TEMPTROL®



Isolation

Process valve
ZETRIX®



Butterfly valve
ZIVA®



Bellows valve
FABA®-Plus, FABA®-Supra I/C



Stop valve with gland seal
STOBU®



Safety

Safety valves (DIN)
SAFE



Safety valves (DIN)
SAFE P

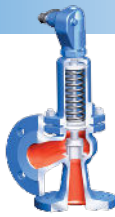

Safety valves (API 526)
ARI-REYCO™

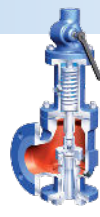

Safety valves
SAFE TCP



Steam trapping

Steam traps (mechanical ball
float / thermostatic / bimetallic
and membrane / thermodynamic)
CONA®

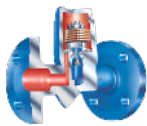

Manifolds
CODI®



Steam trap with multi-valving
technology (incl. stop valve,
strainer, check valve, drain valve)
CONA® "All-in-One"



Steam trap with
monitoring system
CONA®-Control





Rev: 03/2015 - Data subject to change

ARI-Armaturen USA, LP

6614 Dixie Drive
Houston, TX 77087

T 713.845.1500
F 713.845.1515
E sales@ari-armaturenusa.com

www.ari-armaturenusa.com
www.reycovalve.com

